

EE-SX77/87 series

Photo microsensors

Information for ISO13849-1 Compliance

Thank you for selecting OMRON product.

When the product is treated as ISO 13849-1 (PL c, Cat1), please confirm the following:

Before operating the product, please read both this document and the 'Instruction Manual' included with the product together to acquire sufficient product knowledge. It is convenient to keep these documents on hand. When handling, please entrust it to a professional with specialized knowledge.

Terms and Conditions Agreement

Read and understand this catalog.

Please read and understand this catalog before purchasing the products. Please consult your OMRON representative if you have any questions or comments.

Warranties.

- (a) Exclusive Warranty. Omron's exclusive warranty is that the Products will be free from defects in materials and workmanship for a period of twelve months from the date of sale by Omron (or such other period expressed in writing by Omron). Omron disclaims all other warranties, express or implied.
- (b) Limitations. OMRON MAKES NO WARRANTY OR REPRESENTATION, EXPRESS OR IMPLIED, ABOUT NON-INFRINGEMENT, MERCHANTABILITY OR FITNESS FOR A PARTICULAR PURPOSE OF THE PRODUCTS. BUYER ACKNOWLEDGES THAT IT ALONE HAS DETERMINED THAT THE PRODUCTS WILL SUITABLY MEET THE REQUIREMENTS OF THEIR INTENDED USE.

Omron further disclaims all warranties and responsibility of any type for claims or expenses based on infringement by the Products or otherwise of any intellectual property right. (c) Buyer Remedy. Omron's sole obligation hereunder shall be, at Omron's election, to (i) replace (in the form originally shipped with Buyer responsible for labor charges for removal or replacement thereof) the non-complying Product, (ii) repair the non-complying Product, or (iii) repay or credit Buyer an amount equal to the purchase price of the non-complying Product; provided that in no event shall Omron be responsible for warranty, repair, indemnity or any other claims or expenses regarding the Products unless Omron's analysis confirms that the Products were properly handled, stored, installed and maintained and not subject to contamination, abuse, misuse or inappropriate modification. Return of any Products by Buyer must be approved in writing by Omron before shipment. Omron Companies shall not be liable for the suitability or unsuitability or the results from the use of Products in combination with any electrical or electronic components, circuits, system assemblies or any other materials or substances or environments. Any advice, recommendations or information given orally or in writing, are not to be construed as an amendment or addition to the above warranty.

See <http://www.omron.com/global/> or contact your Omron representative for published information.

Limitation on Liability: Etc.

OMRON COMPANIES SHALL NOT BE LIABLE FOR SPECIAL, INDIRECT, INCIDENTAL, OR CONSEQUENTIAL DAMAGES, LOSS OF PROFITS OR PRODUCTION OR COMMERCIAL LOSS IN ANY WAY CONNECTED WITH THE PRODUCTS, WHETHER SUCH CLAIM IS BASED IN CONTRACT, WARRANTY, NEGLIGENCE OR STRICT LIABILITY.

Further, in no event shall liability of Omron Companies exceed the individual price of the Product on which liability is asserted.

Suitability of Use.

Omron Companies shall not be responsible for conformity with any standards, codes or regulations which apply to the combination of the Product in the Buyer's application or use of the Product. At Buyer's request, Omron will provide applicable third party certification documents identifying ratings and limitations of use which apply to the Product. This information by itself is not sufficient for a complete determination of the suitability of the Product in combination with the end product, machine, system, or other application or use. Buyer shall be solely responsible for determining appropriateness of the particular Product with respect to Buyer's application, product or system. Buyer shall take application responsibility in all cases.

NEVER USE THE PRODUCT FOR AN APPLICATION INVOLVING SERIOUS RISK TO LIFE OR PROPERTY OR IN LARGE QUANTITIES WITHOUT ENSURING THAT THE SYSTEM AS A WHOLE HAS BEEN DESIGNED TO ADDRESS THE RISKS, AND THAT THE OMRON PRODUCT(S) IS PROPERLY RATED AND INSTALLED FOR THE INTENDED USE WITHIN THE OVERALL EQUIPMENT OR SYSTEM.

Programmable Products.

Omron Companies shall not be responsible for the user's programming of a programmable Product, or any consequence thereof.

Performance Data.

Data presented in Omron Company websites, catalogs and other materials is provided as a guide for the user in determining suitability and does not constitute a warranty. It may represent the result of Omron's test conditions, and the user must correlate it to actual application requirements. Actual performance is subject to the Omron's Warranty and Limitations of Liability.

Change in Specifications.

Product specifications and accessories may be changed at any time based on improvements and other reasons. It is our practice to change part numbers when published ratings or features are changed, or when significant construction changes are made. However, some specifications of the Product may be changed without any notice. When in doubt, special part numbers may be assigned to fix or establish key specifications for your application. Please consult with your Omron's representative at any time to confirm actual specifications of purchased Product.

Errors and Omissions.



Information presented by Omron Companies has been checked and is believed to be accurate; however, no responsibility is assumed for clerical, typographical or proofreading errors or omissions.

Table of contents

1. Product function	5
1.1 Timing chart.....	6
1.2 Control output/ Operation mode.....	7
1.3 Dimensions	8
2. Safety Precautions	9
2.1 Warning.....	10
2.2 Precautions for Safe Use	10
2.3 Precautions for Correct Use	11
3. Information of standards.....	12
3.1 Compliant Standards	12
3.2 Certification Standards.....	12
3.3 Safety states	12
3.4 Safety-related parameters	12
3.5 Environment conditions.....	12
4. Maintenance Checklist	13
4.1 Daily Inspection Checklist.....	13
4.2 Regular Inspection Checklist	13
4.3 Checklist for Product Replacement.....	13
5. Troubleshooting	14
6. Revision History.	15

1. Product function

EE-SX77/87 series is “photo microsensor” which detects objects that either reflect or interrupt visible or invisible light. The control output is a semiconductor switching element.

Appearance	Standard	L-shaped	T-shaped
Item			
NPN models	EE-SX770/EE-SX870 EE-SX770A/EE-SX870A	EE-SX771/EE-SX871 EE-SX771A/EE-SX871A	EE-SX772/EE-SX872 EE-SX772A/EE-SX872A
PNP models	EE-SX770P/EE-SX870P EE-SX770R/EE-SX870R	EE-SX771P/EE-SX871P EE-SX771R/EE-SX871R	EE-SX772P/EE-SX872P EE-SX772R/EE-SX872R
Sensing distance	5 mm (slot width)		
Standard sensing object * 1	Opaque: 2 × 0.8 mm min.		
Light source (wavelength)	GaAs infrared LED with a peak wavelength of 940 nm		
Response time	Under light incident condition: 20 μs or less Under light interrupted condition: 100 μs or less		
Maximum response frequency	3kHz max.		
Power supply voltage	5VDC -10% to 24VDC +10%, ripple (p-p): 10% max.		
Control output	NPN open collector: 5 to 24 VDC, 100 mA max. 100 mA load current with a residual voltage of 0.8 V max. 40 mA load current with a residual voltage of 0.4 V max. OFF current (leakage current): 0.5 mA max. PNP open collector: 5 to 24 VDC, 50 mA max. 50 mA load current with a residual voltage of 1.3 V max. OFF current (leakage current): 0.5 mA max		
Dielectric strength	AC1,000V, 50/60 Hz for 1 min		
impulse withstand voltage	±1kV		
Current consumption	12 mA max.		
Degree of protection	ISO13849-1 IP64		
Indicators	Light indicator (red) (turns ON when light is interrupted for models with A or R suffix)		

* 1 Please refer to the diagram below for the direction of the standard sensing object.

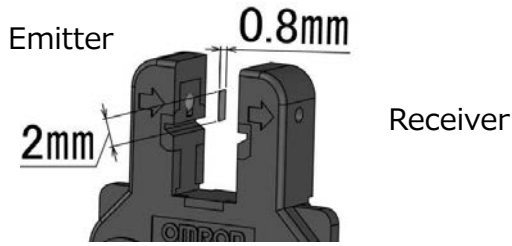

For ratings and specifications other than those described in this document, please refer to the catalog or Instruction Manual.

1.1 Timing chart

EE-SX77/87 timing charts are shown in Figure

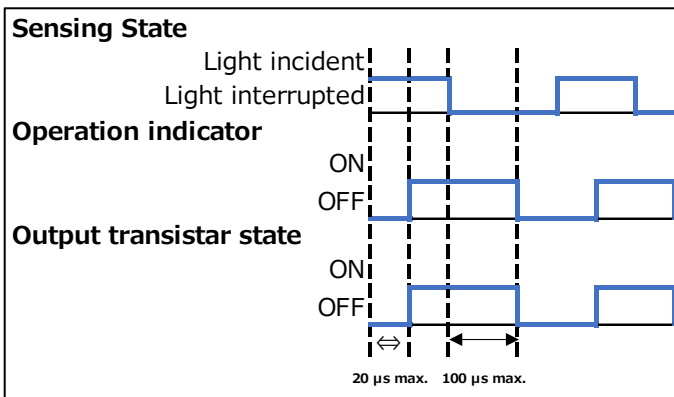

Light ON and Incident light

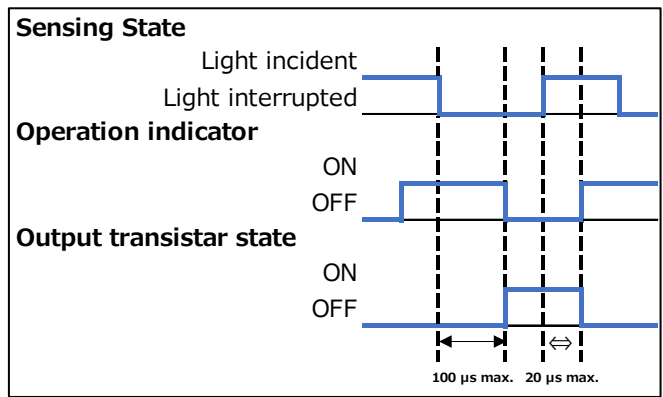

Dark ON and Incident light

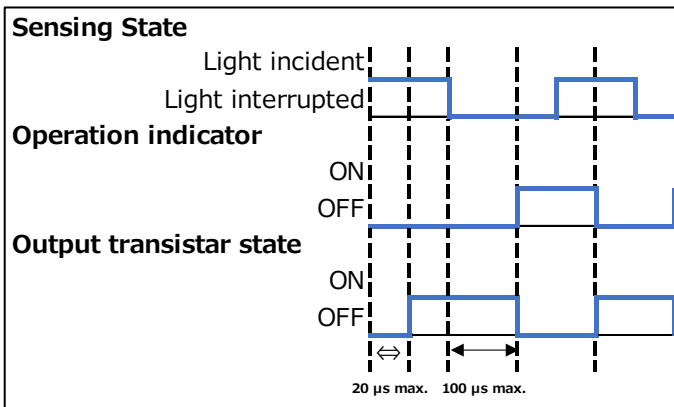

Light ON and No incident light

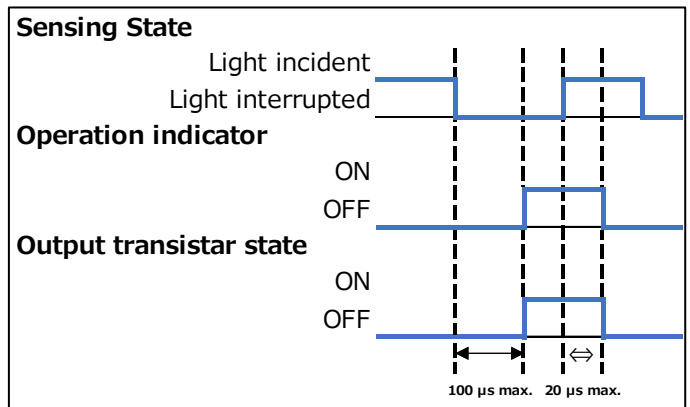

Dark ON and No incident light

1.2 Control output/ Operation mode

Control output is 2 type which is NPN output and PNP output. The operating mode, time chart, and output circuit are shown in the figure below.

NPN Output

Model	Output configuration	Timing charts	Output circuit
EE-SX770 EE-SX771 EE-SX772	Dark-ON		
EE-SX870 EE-SX871 EE-SX872	Light-ON		
EE-SX770A EE-SX771A EE-SX772A	Dark-ON		
EE-SX870A EE-SX871A EE-SX872A	Light-ON		

PNP Output

Model	Output configuration	Timing chart	Output circuit
EE-SX770P EE-SX771P EE-SX772P	Dark-ON		
EE-SX870P EE-SX871P EE-SX872P	Light-ON		
EE-SX770R EE-SX771R EE-SX772R	Dark-ON		
EE-SX870R EE-SX871R EE-SX872R	Light-ON		

The conditions under which the control output is turned on are different.

Operation mode	Output of Light-ON	Output of Dark-ON
Detection Object (Light interrupted)	OFF	ON
No detected object (Light incident)	ON	OFF

1.3 Dimensions

Standard

EE-SX770/770P
 EE-SX870/870P
 EE-SX770A/770R
 EE-SX870A/870R

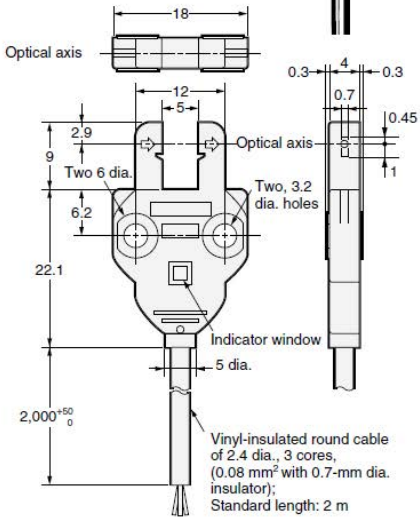

L-shaped

EE-SX771/771P
 EE-SX871/871P
 EE-SX771A/771R
 EE-SX871A/871R

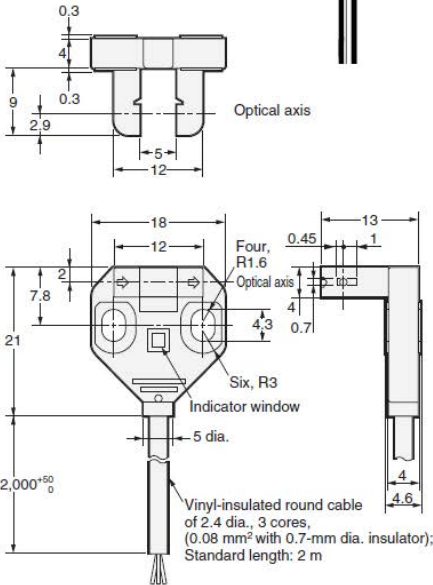

T-shaped

EE-SX772/772P
 EE-SX872/872P
 EE-SX772A/772R
 EE-SX872A/872R

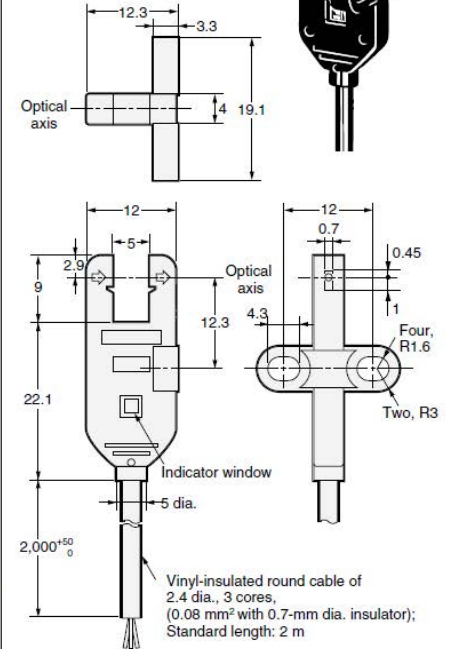





2. Safety Precautions

The EE-SX77/87 series conforms to the international standard ISO 13849-1 (PL c,Cat1). Before operating the product, please read both this document and the 'Instruction Manual' included with the product together to acquire sufficient product knowledge.







The following notation is used in this manual to provide precautions required to ensure safe usage of a EE-SX77/87 series.

 WARNING	<p>Indicates a potentially hazardous situation which, if not avoided, will result in minor or moderate injury, or may result in serious injury or death. Additionally, there may be significant property damage.</p>
<p>Precautions for Safe Use</p>	<p>Indicates precautions on what to do and what not to do to ensure using the product safely.</p>
<p>Precautions for Correct Use</p>	<p>Indicates precautions on what to do and what not to do to ensure proper operation and performance.</p>

The symbols have the following meanings:

	<p>Indicates prohibited actions.</p>
	<p>Indicates mandatory actions.</p>
	<p>Indicates the risk of electric shock</p>
	<p>Indicates the risk of rupture.</p>

2.1 Warning

 WARNING	
Do not connect the EE-SX77/87 to an AC or DC power supply with higher voltage than nominal DC24V. Otherwise, the sensor may explode, burn, or cause electric shock.	 
This product is not designed to be used either directly in applications that detect human presence for the purpose of maintaining safety. Do not use this product in sensing devices designed to be provide directly human safety.	
Use an opaque test rod with 2×0.8mm in diameter. The EE-SX77/87 cannot detect transparent materials.	
Do not install the EE-SX77/87 in a location where it can be affected by wall reflections to avoid detection failure, which may result in serious injury.	
Wiring must be done while the power is turned OFF. Doing it with the power ON may cause an electric shock.	

2.2 Precautions for Safe Use

Precautions for Safe Use
Be sure to follow the safety precautions below for added safety. (1) Do not use the sensor under the environment with explosive or ignition gas. (2) Never disassemble, repair nor tamper with the product. (3) Do not apply voltage more than the rated voltage. (4) Do not use the sensor over the rated values. (5) When you discard the product, please process industrial waste.

2.3 Precautions for Correct Use

Precautions for Correct Use	
Do not use the product in atmospheres or environments that exceed product ratings.	
Wiring	<p>The maximum power supply voltage is 26.4 VDC. Before turning the power ON, make sure that the power supply voltage is not more than maximum voltage.</p> <p>Load short-circuit protection</p> <p>The EE-SX77/87 incorporates a load short-circuit protection function. If the load short-circuits, the output of the EE-SX77/87 will be turned OFF. Then, recheck the wiring and turn on the EE-SX77/87 again to reset the load short-circuit protection function. The load short-circuit protection function will work if there is a current flow that is 1.1 times larger than the rated load current. When using a capacitance load, be sure that the inrush current will not exceed 1.1 times larger than the rated current.</p>
Mounting	<p>When mounting the Sensor, never strike it with a heavy object, such as a hammer.</p> <ul style="list-style-type: none">•Mount the Sensors securely on a surface.•Mount the Sensor with two M3 screws, using a spring washer to ensure the screws will not become loose. Use a tightening force of 6 kgf·cm (0.59 N·m) max.
Others	<p>Do not use the product under the following conditions.</p> <ul style="list-style-type: none">•In the place exposed to the direct sunlight.•In the place where humidity is high and condensation may occur.•In the place where corrosive gas exists.•In the place where vibration or shock is directly transmitted to the product.

3. Information of standards

3.1 Compliant Standards

- EMC: IEC60947-5-2:2019
- Low Voltage: IEC60947-5-2:2019

3.2 Certification Standards

UL: UL508 File No.E41515 CCN NRNT2

TUV: ISO13849-1:2023(Cat 1, PL c), IEC60947-5-2:2019

3.3 Safety states

In case of EE-SX77/87 failure, safety state is Output transistor OFF.

3.4 Safety-related parameters

Parameter	EE-SX77/87
Output short-circuit protection	Yes
MTTF _d	100 years max.
PFH _d [1/h]	1.37×10^{-7}
DC _{avg}	0
T _M	20years
Response time	Light incident: 20 μs or less Light interrupted: 100 μs or less

3.5 Environment conditions

Parameter	EE-SX77/87
Ambient temperature	Operation: -25 to +55 °C, Storage: -30 to +80 °C (with no condensing environment)
Ambient humidity	Operation: 5 to 85 % RH, Storage: 5 to 95 % RH (with no condensing environment)
Ambient illuminance	fluorescent lamp: 1,000 lx or less at the light-receiving face
Altitude	2000m max.
Pollution degree	3

4. Maintenance Checklist

WARNING

Please perform daily and periodic inspections for all EE-SX77/87 units. Operating this device without performing the inspection or without removing the abnormal condition may cause death or serious injury. Inspections and replacements should be based on your own safety and the risk assessment of the entire application.

4.1 Daily Inspection Checklist

Control output shall operate as follows:

- (Light-On Type) Output is ON when light is interrupted or OFF when light is incident.
- (Dark-On Type) Output is OFF when light is interrupted and ON when light is incident.

The operation indicator light shall exhibit the following behavior:

- (Light-On Type): The indicator light turns ON when light is incident and turns off when light is interrupted.
- (Dark-On Type): The indicator light turns OFF when light is incident and turns off when light is interrupted.
- Do not install equipment that generates external light disturbance, reflected light in the surroundings.
- Safety equipment, such as safety covers, is not damaged.

4.2 Regular Inspection Checklist

- Wiring from this product is correct.
- There is no looseness in the screws related to this product, and connectors are not disconnected.
- The detection surface (lens) of the product is not dirty

4.3 Checklist for Product Replacement

Control output shall operate as follows:

- (Light-On Type) Output is ON when light is interrupted or OFF when light is incident.
- (Dark-On Type) Output is OFF when light is interrupted and ON when light is incident.

The operation indicator light shall exhibit the following behavior:

- (Light-On Type): The indicator light turns ON when light is incident and turns off when light is interrupted.
- (Dark-On Type): The indicator light turns OFF when light is incident and turns off when light is interrupted.
- Wiring from this product is correct.
- There is no looseness in the screws related to this product, and connectors are not disconnected.

*Please confirm the inspection frequency for the entire application based on your own risk assessment.

* If any abnormalities are found during the inspection, please refer to "5. Troubleshooting".

5. Troubleshooting

If the product is not operating or if there are abnormalities such as the output not switching ON/OFF, please take the following measures.

Trouble Contents	Cause and measures
Indicator does not illuminate.	There may be no power supply voltage. Please supply DC5~24V to the power supply voltage.
	There may be a wiring error. Please refer to the output circuit diagram for '1.1 Control output/Operating mode' and ensure correct wiring.
	If the above measures do not restore operation, there may be a product malfunction. Do not use the product and replace it.
The control output is not switching ON/OFF.	There may be a short circuit with other signal lines to the control output. Please ensure the control output is correctly wired.
	The load may be short-circuited, and the load short-circuit protection function may be activated. Please check the condition of the load and ensure correct wiring.
	The load current may exceed the rated value, and it is possible that the load short-circuit protection function is working properly. Please check the load you are using.
	If the above measures do not restore operation, there may be a product malfunction. Do not use the product and replace it.

6. Revision History.

Revision symbol	Revision date	Revisions
01	October, 2023	First release
02	December, 2025	Correction of errors (Chapter 2.1 and Chapter 5)
03	March, 2026	Remove the description regarding S-mark compliance from the Ratings/Characteristics section.

OMRON Corporation Industrial Automation Company

Kyoto, JAPAN

Contact : www.ia.omron.com

Regional Headquarters

OMRON EUROPE B.V.

Wegalaan 67-69, 2132 JD Hoofddorp
The Netherlands
Tel: (31) 2356-81-300 Fax: (31) 2356-81-388

OMRON ELECTRONICS LLC

2895 Greenspoint Parkway, Suite 200
Hoffman Estates, IL 60169 U.S.A.
Tel: (1) 847-843-7900 Fax: (1) 847-843-7787

OMRON ASIA PACIFIC PTE. LTD.

438B Alexandra Road, #08-01/02 Alexandra
Technopark, Singapore 119968
Tel: (65) 6835-3011 Fax: (65) 6835-3011

OMRON (CHINA) CO., LTD.

Room 2211, Bank of China Tower,
200 Yin Cheng Zhong Road,
PuDong New Area, Shanghai, 200120, China
Tel: (86) 21-6023-0333 Fax: (86) 21-5037-2388

Authorized Distributor:

©OMRON Corporation 2023-2026 All Rights Reserved.
In the interest of product improvement, specifications are
subject to change without notice.

Cat. No. Z485-E1-03 0426 (1023)