

SmartController EX

User's Guide



Copyright Notice

The information contained herein is the property of Omron Adept Technologies, Inc., and shall not be reproduced in whole or in part without prior written approval of Omron Adept Technologies, Inc. The information herein is subject to change without notice and should not be construed as a commitment by Omron Adept Technologies, Inc. The documentation is periodically reviewed and revised.

Omron Adept Technologies, Inc., assumes no responsibility for any errors or omissions in the documentation. Critical evaluation of the documentation by the user is welcomed. Your comments assist us in preparation of future documentation. Please submit your comments to: techpubs@adept.com.

Copyright 2013, 2014, 2016, 2019 by Omron Adept Technologies, Inc. All rights reserved.

Any trademarks from other companies used in this publication
are the property of those respective companies.

Created in the United States of America

Table of Contents

Chapter 1: Introduction	7
1.1 Product Description	7
Optional T20 Pendant	7
1.2 How Can I Get Help?	9
Related Manuals	9
Chapter 2: Safety	11
2.1 Dangers, Warnings, and Cautions	11
Alert Levels	11
Alert Icons	11
Special Information	12
2.2 What to Do in an Emergency / Abnormal Situation	12
Stopping the Robot	12
Fire Response	12
2.3 Safety Precautions	12
2.4 Additional Safety Information	12
Manufacturer's Declarations	12
Robot Safety Guide	13
Emergency Stop Circuit and Buttons	13
Manual Control Pendant	13
2.5 Disposal	13
Chapter 3: Installation	15
3.1 Controller Installation	15
Before Unpacking	15
Upon Unpacking	15
Repacking for Relocation	16
Space Around the Chassis	16
Mounting the SmartController EX Motion Controller	16
Mounting Kits	16
Memory Card	20
3.2 Connecting Power	22
24 VDC Power Specifications	22
24 VDC Power Cabling	23
DC Power Connectors	24
Chassis Grounding	24
Installing 24 VDC Connectors	25
3.3 System Cable Installation	26

IEEE 1394 Cable Specifications	26
Chapter 4: Operation	27
4.1 Connectors and Indicators	27
4.2 Front Panel	31
4.3 Installing the ACE Software	32
4.4 Configuring the SmartController	33
Configuring Serial Ports	33
RS-232 Connectors	34
RS-422 / 485 Connector	34
4.5 Connecting User-Supplied Safety and Power-Control Equipment	35
Emergency Stop Circuits	41
Remote Manual Mode	43
User Manual / Auto Indication	43
User High Power On Indication	43
Remote High Power ON / OFF Control	43
High Power ON / OFF Lamp	44
Remote Front Panel or User-Supplied Control Panel Usage	44
Remote Pendant Usage	45
4.6 Connecting User-Supplied Digital I/O Equipment	45
DeviceNet Connector	45
XDIO Connector	45
4.7 Belt Encoder Interface	51
Chapter 5: Technical Specifications	55
5.1 SmartController EX Motion Controller Dimensions	55
5.2 Front Panel Dimensions	56
5.3 T20 Pendant Dimensions	57
Chapter 6: DeviceNet	59
6.1 DeviceNet Specifications	59
6.2 Limitations of the DeviceNet Scanner	60
6.3 DeviceNet Port on the Controller	60
Connecting DeviceNet Hardware to the Controller	60
Configuring DeviceNet	61
6.4 DeviceNet Physical Layer and Media	61
DeviceNet Connectors	65
Termination of the DeviceNet Network	66
Power Supply and the DeviceNet Bus	67

Revision History

Revision code	Date	Revised Content
01	June, 2016	Original release
02	October, 2016	Added OAT part number for non-Omron sales channels, updated Omron logo in graphics
03	March, 2019	<ul style="list-style-type: none">• Added WEEE disposal information.• Updated all www.adept.com references to www.ia.omron.com.• Updated copyright for 2019.• Added information about optional Mounting Kits.• Removed references to obsolete sDIO unit.• Removed daisy-chaining power supply details.• Updated ACE Software installation procedure.• Updated illustrations with call-outs for translation compatibility and other minor improvements.• Updated Chapter 2: Safety with new format and information.• Replaced discontinued S8JX-G power supply with replacement S8FS-G series.

Chapter 1: Introduction

1.1 Product Description

The SmartController EX motion controller is a member of the Omron Adept Technologies, Inc. family of high-performance distributed motion controllers. The SmartController is designed for use with Quattro, Hornet, eCobra, and Viper robots.



Figure 1-1. SmartController EX Motion Controller

Optional T20 Pendant

The optional T20 pendant provides a user interface and teach pendant in an ergonomic and rugged package. The pendant is designed for right- or left-handed use. All gripping and holding positions enable comfortable and fatigue-free operation.

The safety features include:

- Emergency-stop switch (dual-channel circuit)
- 3-position enable switch (dual-channel circuits)

See the T20 Pendant User's Guide, shipped with each pendant, for complete information on the product.



Figure 1-2. T20 Pendant

1.2 How Can I Get Help?

For details on getting assistance with your software or hardware, you can access the following corporate website:

<http://www.ia.omron.com>

Related Manuals

This manual covers the installation and maintenance of a SmartController EX motion controller. There are additional manuals that cover programming the system, reconfiguring installed components, and adding other optional components. The following manuals provide information on advanced configurations and system specifications.

Table 1-1. Related Manuals

Manual Title	Description
Robot Safety Guide	Contains safety information for Omron Adept Technologies, Inc. robots.
T20 User's Guide	Contains information on the installation and operation of the T20 pendant.
ACE User's Guide	Describes installation and use of the ACE software.
eV+ OS User Guide	Describes the eV+ operating system, including disk file operations, monitor commands, and monitor command programs.
eV+ Language User's Guide	Describes the eV+ language and programming of our control system.

2.1 Dangers, Warnings, and Cautions

Alert Levels

There are three levels of alert notation used in our manuals. In descending order of importance, they are:



DANGER: Identifies an imminently hazardous situation which, if not avoided, is likely to result in serious injury, and might result in fatality or severe property damage.



WARNING: Identifies a potentially hazardous situation which, if not avoided, will result in minor or moderate injury, and might result in serious injury, fatality, or significant property damage.





CAUTION: Identifies a potentially hazardous situation which, if not avoided, might result in minor injury, moderate injury, or property damage.

Alert Icons

The icon that starts each alert can be used to indicate the type of hazard. These will be used with the appropriate signal word - Warning or Caution - to indicate the severity of the hazard. The text following the signal word will specify what the risk is, and how to avoid it.

Table 2-1. Alert Icon Meaning

Icon	Meaning
	This is a generic alert icon. Any specifics on the risk will be in the text following the signal word.
	This identifies a hazardous electrical situation.

Special Information

There are several types of notation used to call out special information.

IMPORTANT: Information to ensure safe use of the product.

NOTE: Information for more effective use of the product.

Additional Information: Offers helpful tips, recommendations, and best practices.

Version Information: Information on differences in specifications for different versions of hardware or software.

2.2 What to Do in an Emergency / Abnormal Situation

Stopping the Robot

Press any E-Stop button (a red push-button on a yellow background) and then follow the internal procedures of your company or organization for an emergency situation.

Fire Response

If a fire occurs, use CO₂ to extinguish the fire.

2.3 Safety Precautions



WARNING: ELECTROCUTION RISK

During maintenance, disconnect AC power from the robot, and install a lock-out tag-out to prevent anyone from reconnecting power.



WARNING: PERSONAL INJURY OR PROPERTY DAMAGE RISK

An industrial robot can cause serious injury or death, or damage to itself and other equipment, if the safety precautions in this manual are not observed.

2.4 Additional Safety Information

We provide other sources for more safety information:

Manufacturer's Declarations

This lists the standards with which the robots and controllers comply. The Manufacturer's Declarations are in the Manufacturer's Declaration Guide.

Robot Safety Guide

The Robot Safety Guide provides detailed information on safety for our robots. It also gives resources for more information on relevant standards. It ships with each robot.

Emergency Stop Circuit and Buttons

The E-Stop provided complies with ISO 10218-1 (Clause 5.5.2), with stop category 1 (per IEC 60204). The E-stop button complies with ISO 13850. The E-Stop meets the requirements of PL-d per ISO 13849.

If you design your own front panel, it must meet the requirements of ISO 13849, and be at least PL-d. The E-Stop button must comply with IEC 60204-1 and ISO 13850, Clause 5.5.2.

If you choose to use your own E-Stop buttons, they must meet the requirements of IEC 60204-1 and ISO 13850, Clause 5.5.2.

Manual Control Pendant

The protective stop category for the pendant enable switch is category 1, which complies with the requirements of ISO 10218-1.

The pendant is designed in accordance with the requirements of IEC 60204-1 and ISO 13849. The E-Stop button is ISO 13850 compliant.

NOTE: Omron Adept Technologies, Inc. does not offer a cableless (wireless) pendant.

The manual control pendant can only move one robot at a time, even if multiple robots are connected to a SmartController EX, and the pendant is connected to the SmartController EX.

2.5 Disposal



Dispose of in accordance with applicable regulations.

Customers can contribute to resource conservation and protecting the environment by the proper disposal of WEEE (Waste Electronics and Electrical Equipment). All electrical and electronic products should be disposed of separately from the municipal waste system via designated collection facilities. For information about disposal of your old equipment, contact your local Omron support.

Chapter 3: Installation

3.1 Controller Installation

This equipment must be shipped and stored in a temperature-controlled environment. See the following table. It should be shipped and stored in the original packaging, which is designed to prevent damage from normal shock and vibration. You should protect the package from excess shock and vibration.

Table 3-1. Environmental Specifications

Ambient temperature	5° to 40° C (41° to 104° F)
Storage and shipment temperature	-25° to 55° C (-13° to 131° F)
Humidity range	5 to 90%, non-condensing
Altitude	up to 1000 m (3280 ft)
Free space around controller (for proper cooling)	10 mm at back, 13 mm on sides (0.4 in., 0.5 in.)
Chassis protection class	IP20 (NEMA Type 1)



WARNING: Use an appropriate IP-rated enclosure.

Before Unpacking

Carefully inspect all shipping containers for evidence of damage during transit. If any damage is indicated, request that the carrier's agent be present at the time the container is unpacked.

Upon Unpacking

Compare the actual items received (not just the packing slip) with your equipment purchase order, and verify that all items are present and that the shipment is correct. Inspect each item for external damage as it is removed from its container. Contact Omron Adept Technologies, Inc. immediately if any damage is evident.

Retain all containers and packaging materials. These items may be needed in the future to settle a damage claim.

Perform the following steps to unpack the SmartController EX motion controller and optional pendant. Refer to the following sections for information on mounting the equipment.

1. Remove the SmartController EX motion controller from its box. Place it near the robot or mount it in a rack. For details, see [Mounting the SmartController EX Motion Controller](#) on page 16.
2. Remove the optional T20 pendant from its box and place it on a flat surface near the SmartController EX motion controller.

Repacking for Relocation

If the controller needs to be relocated, reverse the steps in the installation procedure. Reuse all original packing containers and materials and follow all safety notes used for installation. Improper packaging for shipment will void your warranty.

Space Around the Chassis

When the SmartController EX motion controller is installed, you must allow 10 mm at the back of the unit and 13 mm on the sides of the unit for proper air cooling.

Mounting the SmartController EX Motion Controller

The following mounting options are available for the controller:

- Rack
- Panel
- Table
- Stack

The controller and compatible units can be mounted with one unit placed on top of another.

NOTE: To maintain compliance with many standards, the mounting of the controller and all terminations at the controller must be performed in accordance with local and national regulations.

Mounting Kits

The following mounting kits are available (order separately).

Table 3-2. Mounting Kit Details

Item	Part Number	Contents
Table / Rack-Mounting Kit	00205-000	<ul style="list-style-type: none">• brackets (table-mount): 4 x 40356-00001• brackets (rack-mount): 2 x 40356-00004• fasteners: 8 x 51052-65006
Panel-Mounting Kit	90356-40000	<ul style="list-style-type: none">• brackets: 4 x 40356-00000• fasteners: 8 x 51052-65006

Rack-Mounting the SmartController EX Motion Controller

To rack-mount the controller in a standard 19-inch equipment rack, install the optional mounting brackets on the side of the controller, as shown in the following figure. These brackets must be ordered separately. They do not come with the controller.

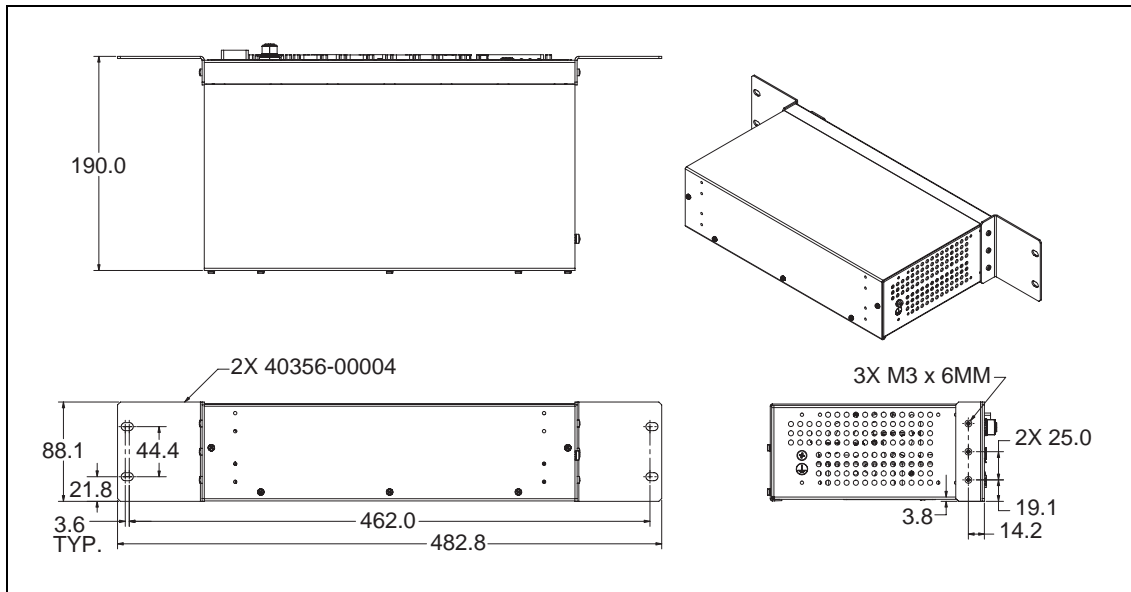

Figure 3-1. Rack-Mounting the SmartController EX Motion Controller (Units in mm)

Panel-Mounting the SmartController EX Motion Controller

To panel-mount the controller, install two brackets on each side at the rear of the unit, as shown in the following figure. Use the screws from the accessories kit.

3.1 Controller Installation

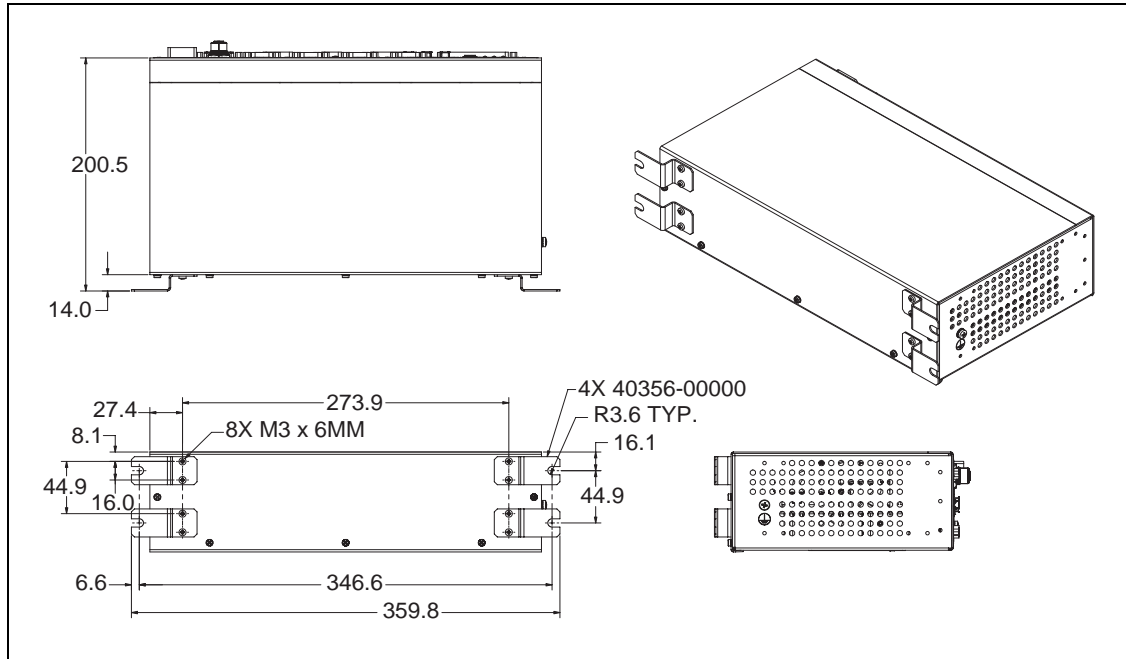

Figure 3-2. Panel-Mounting the SmartController EX Motion Controller (Units in mm)

Table-Mounting the SmartController EX Motion Controller

To table-mount the controller, install two brackets on each side near the bottom of the unit, as shown in the following figure. These brackets must be ordered separately. They do not come with the controller.

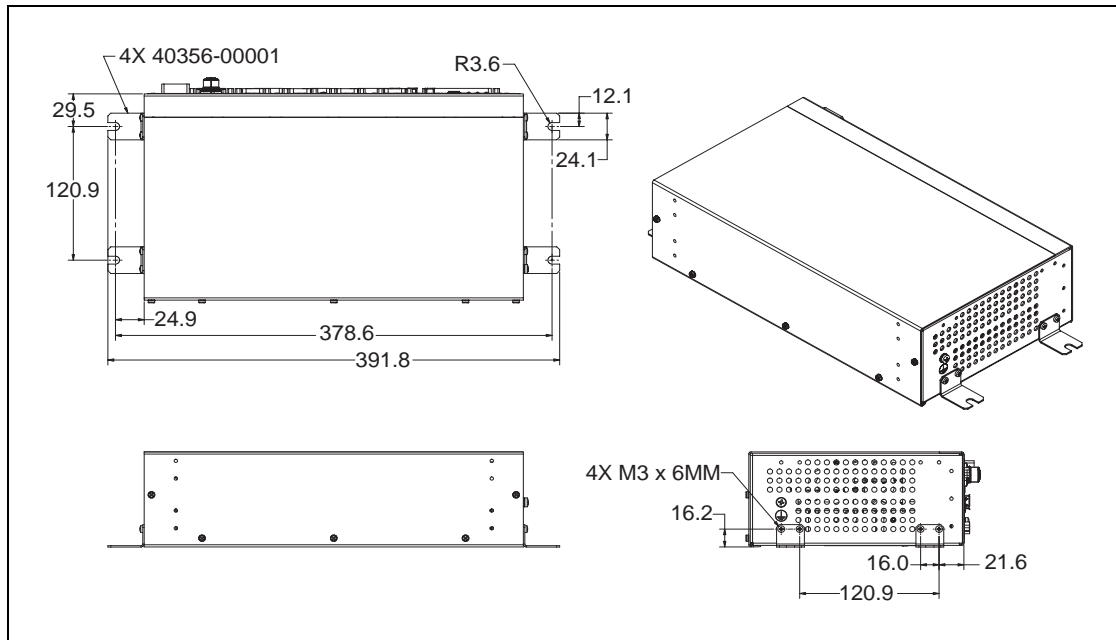

Figure 3-3. Table-Mounting the SmartController EX Motion Controller (Units in mm)

Stack-Mounting Components

To stack-mount the SmartController EX motion controller and a compatible unit, such as a SmartVision MX vision controller, install two brackets on each side of the units, as shown in the following figure. These brackets are supplied with compatible units.

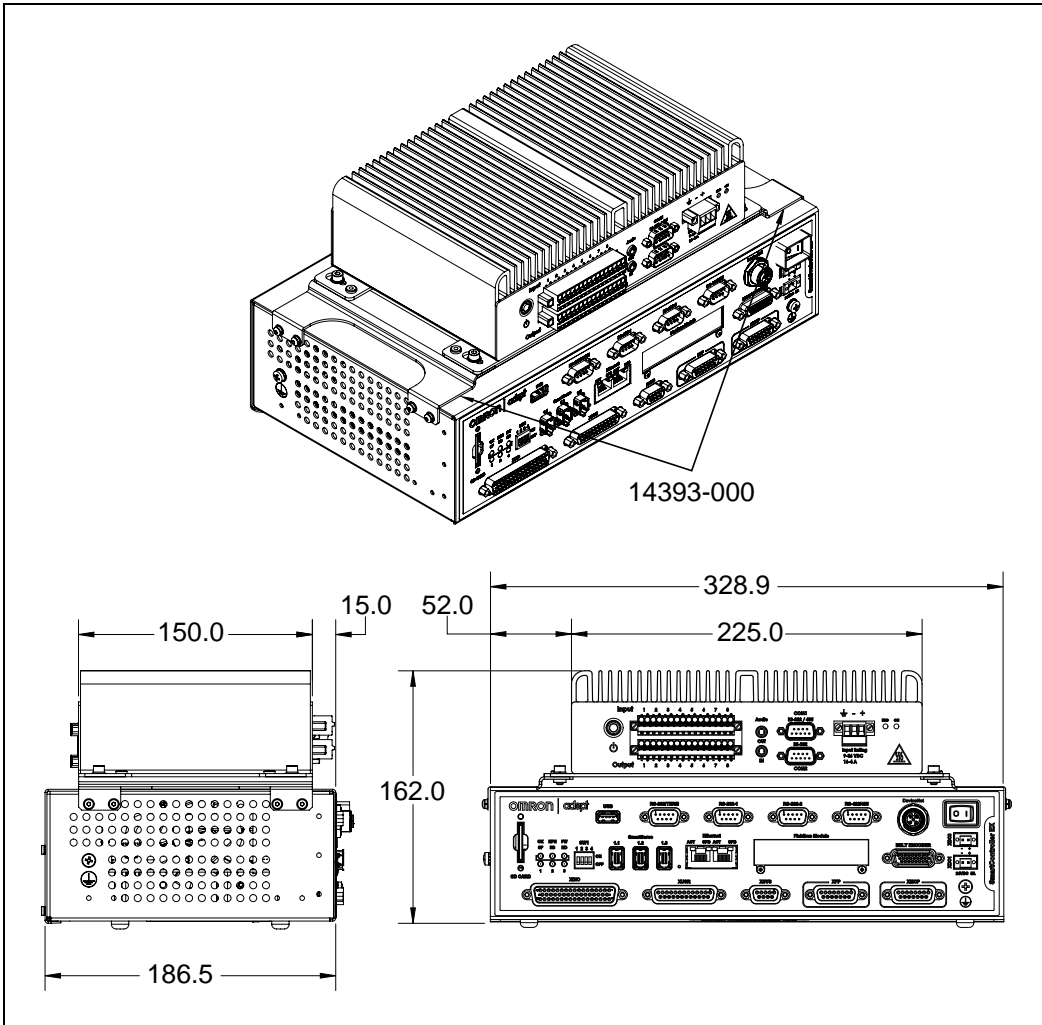

Figure 3-4. Stack-Mounting SmartController EX Motion Controller (Units in mm)

Memory Card

The SmartController EX motion controller is equipped with a Secure Digital™ (SD) memory card. The SD card is removable, and can be moved to another SmartController EX motion controller for testing.

The SD card shipped with all systems is factory-configured and installed. The SD card stores the eV+ operating system, application programs, data files, and licenses.

Only the factory-supplied SD card will work with the SmartController EX motion controller.

NOTE: This SD card is not compatible with the legacy SmartController CX or CS motion controllers.



CAUTION: Use suitable measures for eliminating electrostatic discharge during removal and installation of the SD card. This includes, but is not limited to, the use of a grounded wrist strap



CAUTION: Do not remove the SD card when power is connected to the controller.

Removing an SD Card

To remove an SD card from a SmartController EX motion controller:

1. Make sure that the controller is disconnected from its power source.
2. Locate the SD compartment (see the following figure).

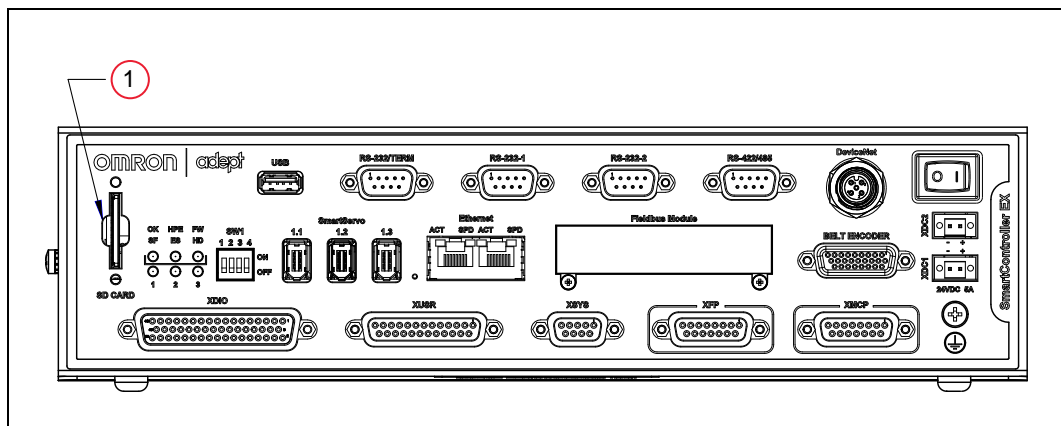

Figure 3-5. (1) SD Memory Card Compartment

NOTE: If you are replacing an existing SD, the original must be sent to the factory for replacement.

3. Press the SD card in, and release. The card will pop out.
Remove the card. Contact your sales representative for instructions on returning it.

Installing an SD Card

To install an SD card into a SmartController EX motion controller:

1. Make sure that the controller is powered off.
2. Locate the SD card compartment (see the preceding figure).
3. Carefully remove the SD card from the READ ME FIRST box or shipping container.

Position the card so its contacts are facing towards the controller and to the left. The label will be facing to the right.

4. Insert the SD card into the controller.

Once installed, we recommend that you do not repeatedly remove and insert the SD card.

3.2 Connecting Power

The SmartController EX motion controller requires filtered 24 VDC power.

NOTE: Users must provide their own power supply. Make sure the power cables and power supply conform to the specifications that follow.

24 VDC Power Specifications

Table 3-3. Specifications for 24 VDC User-Supplied Power Supply

User-Supplied Power Supply	24 VDC (-10%, +5%), 120 W (5 A)
Circuit Protection	Not more than 8 A (below the amperage rating of the cable used)
Power Cabling	1.5 - 1.85 mm ² (16-14 AWG), full-cover, braided shield cable, maximum length 10 meters
Shield Termination	Braided shield connected to the marked frame ground screw on the right side of the controller (near the XDC connector). On the other end of the cable, the shield should be connected to the power supply chassis.

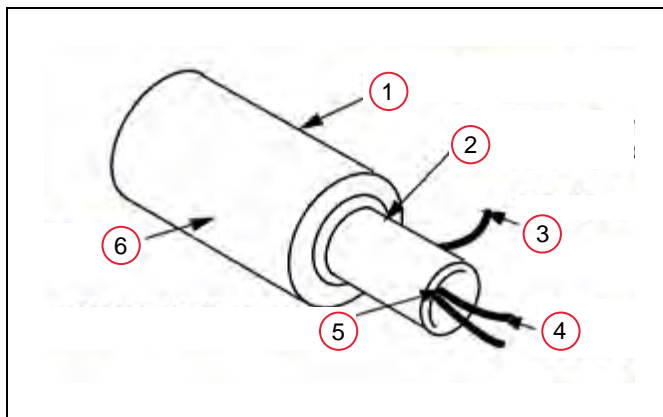

Figure 3-6. User-Supplied 24 VDC Cable

Table 3-4. User-Supplied 24 VDC Cable

Item	Description
1	11 mm (0.43 in) Outside diameter
2	65% Coverage tinned copper braid shield
3	Shield drain wire
4	DC power pair PVC (16-14 AWG tinned and stranded copper conductors)
5	Aluminum / Mylar shield over each pair
6	External jacket



CAUTION: Make sure you select a 24 VDC power supply that meets the specifications in the preceding table. Using an underrated supply can cause system problems and prevent your equipment from operating correctly. See the following table for recommended power supplies.

Table 3-5. Recommended 24 VDC Power Supplies

Vendor Name	Model	Ratings	Mount
OMRON	S8FS-G15024C	24 VDC, 6.5 A, 150 W	Side/Bottom
OMRON	S8FS-G15024CD	24 VDC, 6.5 A, 150 W	DIN-Rail Mount

NOTE: The power requirements for the user-supplied power supply will vary depending on the configuration of the SmartController EX motion controller and connected devices. A minimum configuration of the controller, front panel, and pendant will require 2 A at 24 VDC. However, a 24 V, 5 A power supply is recommended to allow for additional current draw from connected devices, such as external IEEE 1394 devices and digital I/O loads.

24 VDC Power Cabling

In order to maintain compliance with many standards, DC power must be delivered over a shielded cable, with the shield connected to the frame ground at both ends of the cable, as shown in the following figure. Conductors should be 1.5 mm² to 1.85 mm² (16 to 14 AWG) in size. The maximum length for the 24 VDC cable is 10 meters.

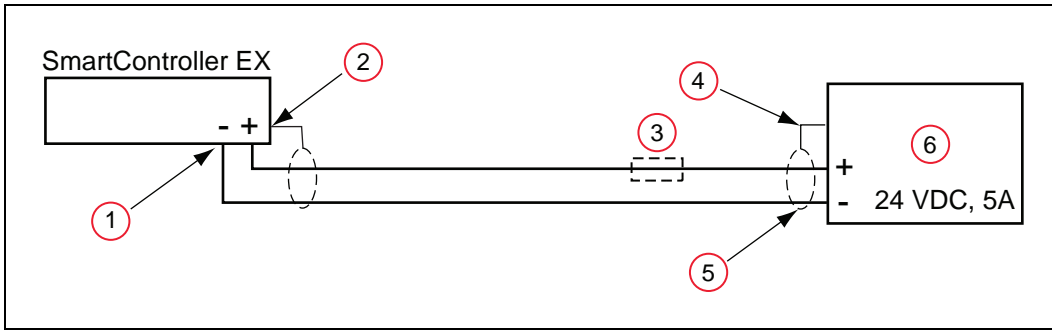

Figure 3-7. User-Supplied Shielded Power Cable

Table 3-6. User-Supplied Shielded Power Cable Description

Item	Description
1	User supplied connector
2	Shield from cable, star washer M3 x 6 screw
3	Optional fuse
4	Frame ground
5	Shield from cable to frame ground on power supply
6	User-provided power supply

DC Power Connectors

The SmartController EX motion controller is equipped with two DC power connectors. DC power can be applied to either the XDC1 or XDC2 connector.



CAUTION: Use only one 24 VDC power supply per circuit. Failure to do this could result in damage to the equipment.



CAUTION: The SmartVision MX vision controller has a higher current demand and should be wired independently. Do not daisy-chain its power from a SmartController EX motion controller.

NOTE: The power switch on the SmartController EX motion controller will shut down just the controller. The two connectors, XDC1 and XDC2, are always connected to each other, so any device that receives power from XDC1 or XDC2 will maintain power after the controller is shut down.

Chassis Grounding

The SmartController EX motion controller is equipped with a grounding point, as shown in the following figure. We recommend connecting a ground wire from the grounding point on

the controller to earth ground and that all other interconnected components share the same electrical ground potential. The ground wire must meet all local regulations. Additional grounding information for our other products is provided in the documentation for those products.

NOTE: The maximum length for the ground wire for the controller is 3 meters.

NOTE: The resistance of the ground conductor should be $\leq 10 \Omega$.

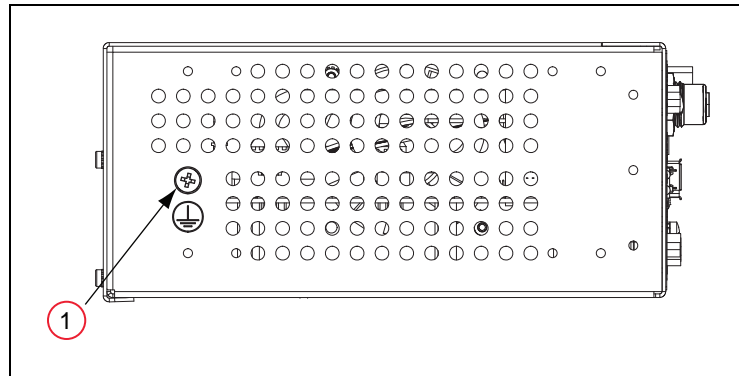

Figure 3-8. (1) Chassis Grounding Point

The mounting of the controller and all terminations must be performed in accordance with local and national regulations.

Installing 24 VDC Connectors

Use the supplied connector to connect the user-supplied 24 VDC power supply to the SmartController EX motion controller.

1. Locate the 24 VDC connector shipped with the controller. See the following figure.
2. Use 14 or 16 gauge wire to connect the 24 VDC power supply to the controller.
3. Strip 7 mm of insulation from the end of the wire that connects to the positive output of the 24 VDC supply.
4. Insert the stripped end into the opening on the right side of the connector.
5. Tighten the screw clamp on the connector with a small slot screwdriver (2.5 mm).
6. Visually inspect the connection to ensure that the clamp has closed on the wire, not on the insulation.
7. Gently pull on the wire to confirm that it is securely attached to the connector.
8. Repeat this process to connect the wire from the negative side of the power supply to the left side of the connector.
9. Connect the braided shield to the ground screw on the front of the controller.

A ring lug can be used, as shown in the following figure. The ground screw is an M3.

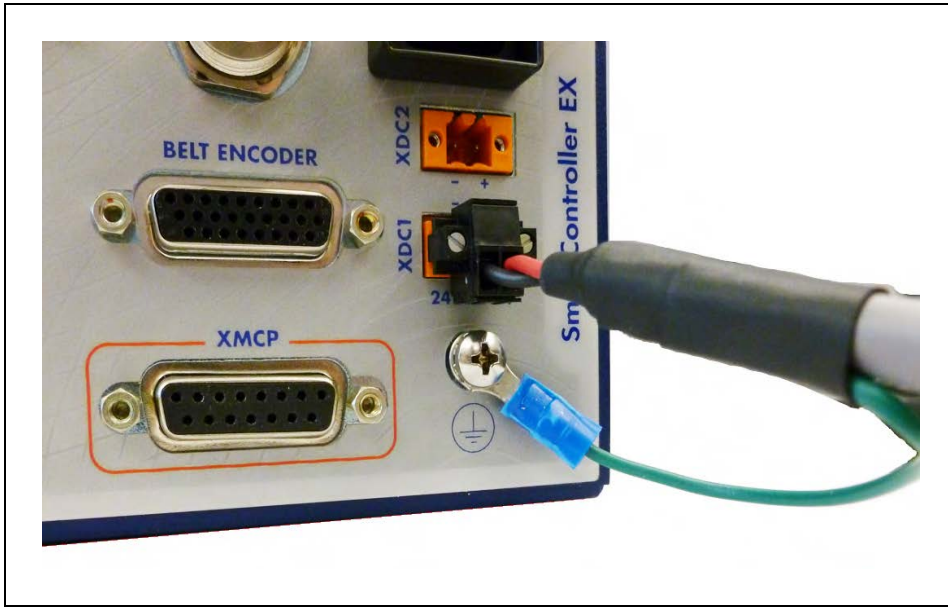

Figure 3-9. 24 V Connector

NOTE: Although no damage will occur, the SmartController EX motion controller will not turn on if the DC polarities on the XDC connectors are reversed.

3.3 System Cable Installation

The SmartController EX motion controller is used in many of our systems, including Hornet robots, eCobra robots, Viper robots, Quattro robots, and the sMI6 Module for the SmartMotion product.

See your specific product manual for complete details on system cabling for your SmartController system.

IEEE 1394 Cable Specifications

We supply the IEEE 1394 cables to connect the SmartController EX motion controller to other devices in the system. If you need a cable of a different length than those supplied, then you must purchase a cable from one of the approved vendors listed below:

- CEI: www.componentsexpress.com
- Molex, Inc.: www.molex.com

These purchased cables must meet all specifications of the IEEE 1394 standard. Note that the system uses 6-pin to 6-pin cables. The maximum length for a 1394 cable is 10 meters. The 1394 Trade Association provides detailed specifications for 1394 cables and other related information. See www.1394ta.org.



WARNING: You must use cables from vendors that meet all specifications of the IEEE 1394 standard. Using a non-approved or inferior quality IEEE 1394 cable can cause unpredictable system performance.

Chapter 4: Operation

4.1 Connectors and Indicators

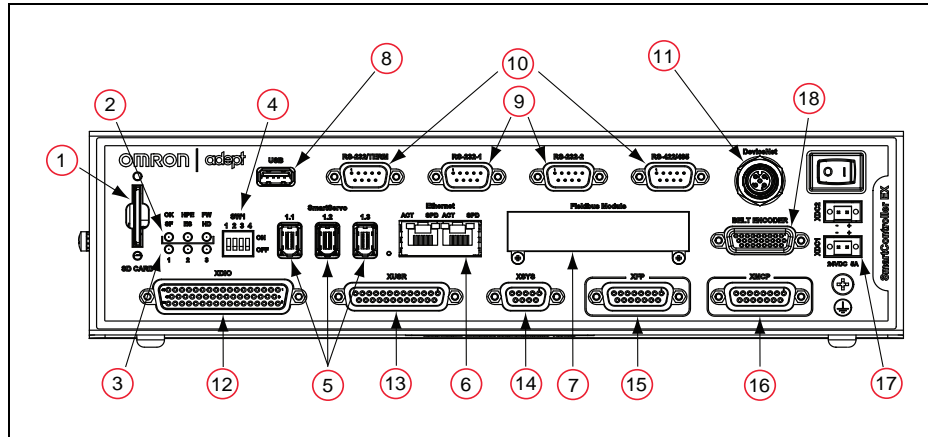

Figure 4-1. SmartController EX Connectors and Indicators

All of the connectors on the SmartController EX motion controller use standard-density spacing, D-subminiature connectors. For customization purposes, the user needs to provide connectors of the appropriate gender and pin count, or purchase optional factory-supplied cables.

1. SD Card Slot

See Installing an SD Card on page 21.

2. Top Three Status LEDs

The top three two-color LEDs indicate diagnostic test, power control, and communication status.

Table 4-1. Controller LEDs

LED	Green Indicates	Red Indicates
OK/SF	System OK	System Fault
HPE/ES	High Power Enabled	E-Stop Open
FW/HD	SmartServo Connection	Read / Write from SD card

During system bootup, the red OK / SF and HPE / ES LEDs are lit and the red FW / HD LED blinks. After system bootup, the OK / SF LED should show green. If the HPE / ES LED shows red, the E-Stop circuit is open. During SD card reads and writes, the FW / HD LED pulses red. When a robot is connected on one of the SmartServo ports, the FW / HD LED shows green.

3. Bottom Three Status LEDs

NOTE: The bottom status LEDs have different meanings when the SmartController is used with ePLC Connect software. See the ePLC Connect User's Guide, chapter 3, for information on those LEDs with ePLC Connect.

The bottom three LEDs on the front of the SmartController EX motion controller give the following information about the status of the main controller.

O = Off G = Green R = Red

Table 4-2. LED Status Indicators

LED Display 1 2 3	Error Number	Description
O-O-O	0	No error.
R-O-O	1	System clock is dead or too fast. Clock interrupts are not being received.
O-R-O	2	Hardware configuration error.
O-O-R	4	Memory test failure. Free storage error.
O-R-R	6	Software serial I/O configuration error.
R-R-R	7	Initial display set by hardware before software has started.
G-O-O	9	Transient display set when PCI is configured.
O-O-G	C	Uninitialized trap.
G-O-G	D	Bus error detected.

If the SmartController EX motion controller displays an error, cycle the power off, then on again. If the problem persists, contact Customer Service.

4. SW1 DIP switches

The definition for DIP switches on the SmartController EX motion controller is as follows:

Switch 1:

- OFF: use IP address from configuration on SD card
- ON: use default factory IP address (printed on the bottom of the controller)

Switch 2:

- OFF: normal connection through Ethernet
- ON: communication through RS-232 on the TERM port

Switch 3 and 4: reserved for future use; always leave in the OFF position.

In normal operation, all switches should be OFF.

5. SmartServo 1.1, 1.2, and 1.3

These ports connect any SmartServo-compatible product to the controller via the IEEE-1394 cable. These ports are interchangeable - any one can be used.



WARNING: Remove power from the controller before plugging in or unplugging any IEEE-1394 cables from these connectors. Failure to remove power could result in unpredictable behavior by the system.

6. Ethernet (Eth 10/100/1000) connectors

The shielded RJ-45 receptacles support 10/100/1000 BaseT Ethernet communications. The two ports are interchangeable.

NOTE: The default IP address for the controller is located on a label on the bottom side of the controller chassis.

7. Fieldbus Module

This module is reserved for future use.

8. USB port

This port is reserved for future use.

9. RS-232-1 and RS-232-2 connectors

These are RS-232 serial ports for general use. See Configuring Serial Ports on page 33 for more information.

10. RS-232 and RS-422 / 485 connectors

These ports support RS-232 and RS-422 / 485 devices, respectively. See Configuring Serial Ports on page 33 for pin descriptions and locations.

11. DeviceNet connector

DeviceNet is a field bus for industrial devices. This standard supports a variety of products, including sensors, digital I/O, analog I/O, RS-232, and PLCs. Other DeviceNet product types, such as keypads and displays, can be controlled using the eV+ FCMD program instruction (see the eV+ Language Reference Guide for details). See DeviceNet on page 59.

12. XDIO connector

This connector includes 20 signal pairs: 8 digital outputs (100 mA max) and 12 digital inputs, all of which are fast inputs. The digital outputs are short-circuit protected. This connector also supplies 24 VDC power for customer equipment. See Connecting User-Supplied Digital I/O Equipment on page 45 for more information.

13. XUSR connector

Provides switch functions for emergency stop (E-Stop) and Manual / Automatic interfaces to external push-buttons and other equipment. For example, an external E-Stop can be connected to the XUSR connector. A line E-Stop from other equipment can be connected. A muted safety gate that causes an E-Stop only in Automatic mode is included.

Also included are contacts to report the status of E-Stop push-buttons and the Manual / Automatic switch.

NOTE: The SmartController EX motion controller ships with a terminator plug attached to the XUSR connector. The terminator plug must be installed in the absence of any user-supplied safety equipment used to close the E-Stop circuit. Save the terminator plug, in case it is needed in the future for troubleshooting.

For more information about the XUSR connector, see Connecting User-Supplied Safety and Power-Control Equipment on page 35.

14. **XSYS connector**

Connects to the XSLV connector on a robot or servo controller.

15. **XFP connector**

Connects to the optional Front Panel. See Connecting User-Supplied Safety and Power-Control Equipment on page 35 for information.

16. **XMCP connector**

The optional T20 pendant plugs into this connector, via the T20 adapter cable, which has the mating connector for the XMCP connector. The controller ships with a terminator plug in the XMCP connector. The plug must be installed in the absence of a pendant or the E-Stop circuit will remain open, and you will not be able to start the system.

17. **24 VDC connectors / switch**

Connect power from a user-supplied 24 VDC power supply to the XDC1 or XDC2 connector (see Connecting Power on page 22). If using an sMI6 module, connect a separate cable from the unused XDC connector on the controller to the XDC1 connector on the sMI6 module.

An ON / OFF switch turns the controller on or off. Any daisy-chained devices will retain power, as the two connectors (XDC1 and XDC2) are connected to each other.

A ground screw is located immediately below the 24 VDC power jacks.

18. **Belt Encoder connector**

This is a 26-pin D-Sub connector for up to four belt encoders in a conveyor-tracking installation. See Belt Encoder Interface on page 51 for more information.

4.2 Front Panel

The following figure shows a Front Panel.

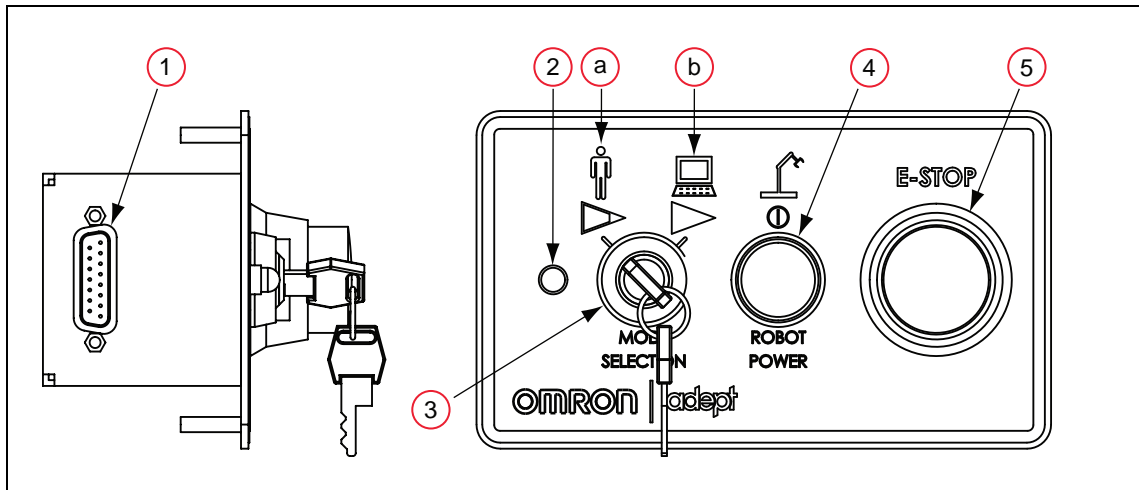

Figure 4-2. Front Panel

Before running programs, either the optional Front Panel or user-supplied switches for High Power ON/ OFF, MAN / AUTO, and E-Stop must be connected to the XFP connector on the SmartController EX motion controller.

NOTE: Safety regulations dictate the sequence of events required for the user to enable high power. For instance, a user may be required to press the High Power On button on the Front Panel after pressing the COMP / PWR button on the pendant or issuing the eV+ Enable Power command. Users cannot jumper this button input and still enable power (see your robot manual for further details).

1. XFP connector

Connects to the XFP connector on the controller.

2. System 5 V Power-On LED

Indicates whether or not power is connected to the Front Panel.

3. Manual / Automatic Mode Switch

Switches between Manual and Automatic mode. In Automatic mode, executing programs control the mechanism, and the mechanism can run at full speed.

In Manual mode, the system limits mechanism speed and torque, to reduce the risk to an operator working in the cell. It is the user's responsibility to determine if this is allowed under local regulations. Manual mode initiates software restrictions on robot speed, commanding no more than 250 mm/sec as required by RIA and ISO standards. Please refer to your robot manual for further details.

- a. Manual Mode
- b. Auto Mode

4. High Power ON / OFF Switch & Lamp

Controls high power, which is the flow of current to the robot motors. Enabling high power is a two-step process. An Enable Power request must be sent from the user terminal, an executing program, or a pendant. Once this request has been made, the button light blinks, and the operator must press the button for high power to be applied. The default timeout for the button is 10 seconds.



WARNING: Disabling the High Power button violates IEC 60204-1. It is strongly recommended that you not alter the use of the High Power button.

5. Emergency Stop Switch

The E-Stop is a dual-channel, passive E-Stop that supports Category 3 PL-d per EN ISO 13849 safety requirements. It maintains motor power for a fixed time after the E-Stop is activated. This feature allows the motors to decelerate under servo control to a stop. This can aid in eliminating coasting or overshooting on low friction mechanisms. It can also aid in the reduction of wear on highly-g geared, high-inertia mechanisms, while maintaining safety compliance per all standards.

4.3 Installing the ACE Software



WARNING: Make sure that all cables are installed correctly and fully inserted and screwed down before applying power to the system. Failure to do this could cause unexpected robot motion. Also, a connector could be pulled out or dislodged unexpectedly.

To begin the installation:

1. Insert the ACE software media into your PC.
 - If AutoPlay is enabled, the Welcome to ACE menu is automatically displayed.
 - If AutoPlay is disabled, you will need to manually start the installation media. Use Windows Explorer to browse to the installation media, right-click on the drive, and select AutoPlay from the menu.
2. Click **Read Important Information**. The ReadMe file is displayed.
3. Verify that your system meets the minimum requirements described in the System Requirements section.
4. After reviewing the information, click the close icon () in the upper-right corner of the ReadMe file window to close it.

NOTE: The online document that describes the installation process opens in the background when you select one of the software installation steps below.

5. Click **Install ACE**. The ACE installer opens.
6. The installer scans your system for prerequisite files. If any files are needed, you will be prompted to acknowledge the installation of those files.
7. Follow the on-screen instructions to complete the installation. You will be prompted to accept the License Agreement and confirm the destination folder for the software installation. Then the installation will proceed.
8. After the installation has completed, you may be prompted to restart your computer.

The ACE software installer adds an "ACE" shortcut to your desktop.

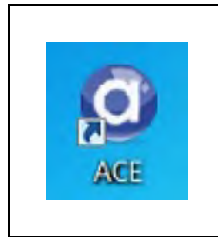

You can also launch ACE from the program group added to the **Omron > ACE** folder on your Windows Programs menu.

4.4 Configuring the SmartController

Configuring Serial Ports

The SmartController EX motion controller has four serial I/O ports:

- RS-232 / Term
- RS-422 / 485
- RS-232-1
- RS-232-2

See Connectors and Indicators on page 27 for the connector locations.

To configure a serial port, use the eV+ FSET program instruction, for example:

```
FSET (lun.num) "/BYTE_LENGTH 8 /STOP_BITS 1 /FLOW XON_XOFF /PARITY
NONE /SPEED 57600"
```

Refer to the eV+ Language User's Guide for more information on FSET. This applies to all of the SmartController EX motion controller's serial ports.

RS-232 Connectors

All three types of RS-232 connectors are 9-pin DB9 male (standard PC) connectors. The user-supplied cable to connect to the RS-232 connectors should be a DB9, F/F, null-modem data-transfer cable. The pin assignments are the same for all three connectors and are shown in the following table.

Table 4-3. RS-232 Connector Pin Assignments

Pin	RS-232-1 & -2		RS-232 / Term	
	Signal	Type	Signal	Type
1	Reserved	-	N/C	-
2	RXD	Input	RXD	Input
3	TXD	Output	TXD	Output
4	Reserved	-	N/C	-
5	GND	Ground	GND	Ground
6	Reserved	-	N/C	-
7	RTS	Output	RTS	Output
8	CTS	Input	CTS	Input
9	Reserved	-	N/C	-

These ports support the RTS and CTS signals used for hardware handshaking (also known as modem control). By default, these signals are not enabled. To configure hardware handshaking and other communication parameters, use the eV+ FSET program instruction. The eV+ designations for these ports, when referenced in the eV+ ATTACH or FSET instructions, are shown in the following table.

NOTE: To configure the port speed and other communications parameters, use the eV+ FSET program instruction.

Table 4-4. Serial Connectors and eV+ Designations

Connector	eV+ Designation
RS-232 / Term	SERIAL:0
RS-232-1	SERIAL:1
RS-232-2	SERIAL:2
RS-422 / 485	SERIAL:3

RS-422 / 485 Connector

The RS-422 / 485 connector is a 9-pin DB9 male connector. The pin assignments are shown in the following table. RS-422 is a point-to-point protocol for connecting to a single destination.

This port can also be configured as a multidrop port (RS-485).

Table 4-5. RS-422 / 485 Connector Pin Assignments

Pin	Signal	Type
1	N/C	
2	RXD+	Input
3	TXD+	Output
4	TXD-	Output
5	GND	Ground
6	RXD-	Input
7	N/C	
8	EXPIO_5V	Output
9	GND	Ground

To change the configuration of the RS-422 / 485 port, see Configuring Serial Ports on page 33. See the previous table for the eV+ designation when referenced in the eV+ ATTACH or FSET instructions.

4.5 Connecting User-Supplied Safety and Power-Control Equipment

The user-supplied safety and power-control equipment connects to the system through the XUSR and XFP connectors on the controller. The XUSR connector (25-pin) and XFP (15-pin) connector are both female D-sub connectors located on the front panel of the controller. Refer to the following table for the XUSR pin-out descriptions. Refer to the table Contacts Provided by the XFP Connector on page 37 for the XFP pin-out descriptions. See the figure CAT-3 E-Stop Circuit on XUSR and XFP Connectors on page 39 for the XUSR wiring diagram.

Table 4-6. Contacts Provided by the XUSR Connector

Pin Pairs	Description	Comments
Voltage-Free Contacts Provided by Customer		
1, 14	User E-Stop CH 1 (mushroom push-button, safety gates, etc.)	N/C contacts, Shorted if NOT Used
2, 15	User E-Stop CH 2 (same as pins 1, 14)	N/C contacts, Shorted if NOT Used
3, 16	Line E-Stop (used for other robot or assembly line E-Stop inter-connection. Does not affect E-Stop indication (pins 7, 20))	N/C contacts, Shorted if NOT Used
4, 17	Line E-Stop (same as pins 3, 16)	N/C contacts, Shorted if NOT Used

4.5 Connecting User-Supplied Safety and Power-Control Equipment

Pin Pairs	Description	Comments
5, 18	Muted Safety Gate CH 1 (causes E-Stop in Automatic mode only)	N/C contacts, Shorted if NOT Used
6, 19	Muted Safety Gate CH 2 (same as pins 5, 18)	N/C contacts, Shorted if NOT Used
Voltage-Free Contacts provided by the System		
7, 20	E-Stop indication CH 1	Contacts are closed when Front Panel, pendant, and customer E-Stops are <i>not</i> tripped
8, 21	E-Stop indication CH 2 (same as pins 7, 20)	Contacts are closed when Front Panel, pendant, and customer E-Stops are <i>not</i> tripped
9, 22	Manual / Automatic indication CH 1	Contacts are closed in Automatic mode
10, 23	Manual / Automatic indication CH 2	Contacts are closed in Automatic mode
11, 12, 13, 24, 25	No connection	

Table 4-7. Contacts Provided by the XFP Connector

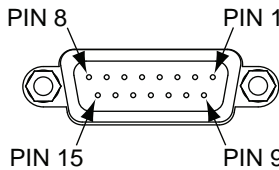
Pin Pairs	Description	Requirements for User-Supplied Front Panel
Voltage-Free Contacts Provided by Customer		
1, 9	Front Panel E-Stop CH 1	User must supply N/C contacts
2, 10	Front Panel E-Stop CH 2	User must supply N/C contacts
3, 11	Remote Manual / Automatic switch CH 1. Manual = Open Automatic = Closed	Optional - jumper closed for Auto Mode-only operation
4, 12	Remote Manual / Automatic switch CH 2. Manual = Open Automatic = Closed	Optional - jumper closed for Auto Mode-only operation
6, 14	Remote High Power ON / OFF momentary push-button	User must supply momentary push-button to enable High Power to system
Non-voltage-Free Contacts		
5, 13	System-Supplied 5 VDC and GND for High Power ON / OFF Switch Lamp	User must supply lamp, or use 1 W, 47 ohm resistor - system will not operate if not present
7, 15 ^a	Controller system 5 V power on LED, 5 V, 20 mA	Optional - indicator only
8	No connection	
		
See the figure Front Panel Schematic on page 41 for a schematic diagram of the Front Panel.		
^a Users must exercise caution to avoid inadvertently connecting 24 V signals to these pins, because this will damage the electronics.		

NOTE: The system was evaluated by Underwriters Laboratory with a factory Front Panel. If you provide a substitute Front Panel, this could void UL compliance.

Table 4-8. Remote Pendant Connections on the XMCP Connector

Pin XMCP (15-Pin D-Sub)	Description
1, 9	Pendant E-Stop Push-button CH 1
2, 10	Pendant E-Stop Push-button CH 2
3, 11	Pendant Enable CH 1 (Hold-to-run)
4, 12	Pendant Enable CH 2 (Hold-to-run)
13	Serial GND / Logic GND
7	Pendant TXD: "eV+ to Pendant TXD"
8	Pendant RXD: "eV+ to Pendant RXD"
14	No connection
15	No connection
Shield	Shield GND
6	24 V
5	No connection

Table 4-9. XSYS Connector Pin Assignments

Pin	Signal	Description
1	ESTOPGND	GND Return
2	MANUAL1	Manual Mode ESTOP Ckt. CH 1
3	MANUAL2	Manual Mode ESTOP Ckt. CH 2
4	HIPWRDIS	High Power Disable
5	HIPWRREQ	High Power Request
6	AUTO1	Auto Mode ESTOP Ckt. CH 1
7	AUTO2	Auto Mode ESTOP Ckt. CH 2
8	N/C	No Connection
9	ESTOPSRC	24 V Output to Slave ESTOP

NOTE: The XSYS connector is used to link the E-Stop system to our robots. It is not intended for customer connections.

The following figure shows an E-Stop diagram for the SmartController EX motion controller. See Emergency Stop Circuits on page 41 for a description of the functionality of this circuit.

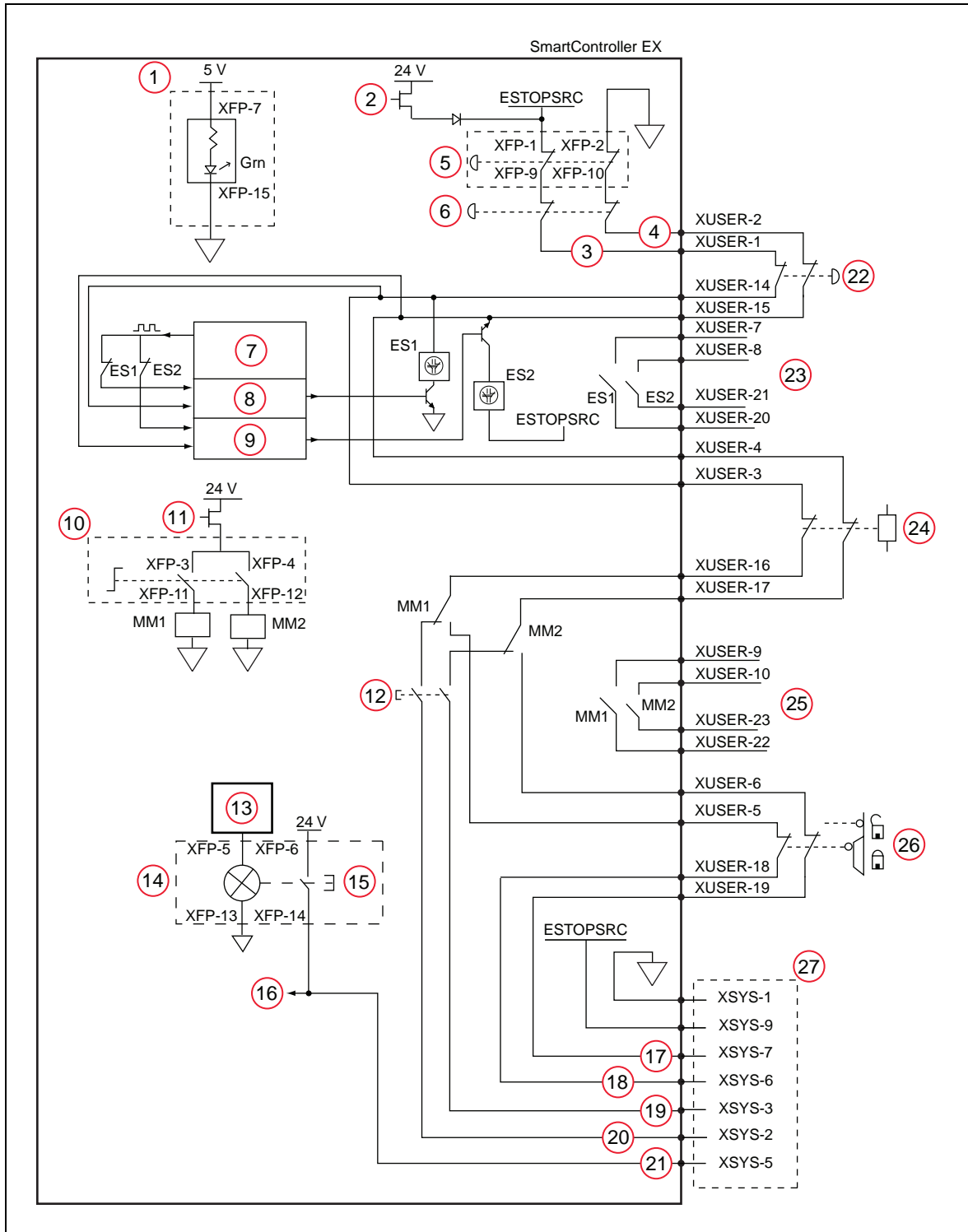

Figure 4-3. CAT-3 E-Stop Circuit on XUSR and XFP Connectors

Table 4-10. CAT-3 E-Stop Circuit on XUSR and XFP Connector Descriptions

Item	Description
1	Front panel system power LED
2	E-Stop enable (current limit 1.4 A max.)
3	Channel 1 (E-Stop)
4	Channel 2 (E-Stop)
5	Front panel E-Stop
6	Pendant E-Stop
7	Logic cyclic check state machines
8	Channel 1 (logic cyclic check state machines)
9	Channel 2 (logic cyclic check state machines)
10	Front panel - Manual / Auto keyswitch
11	Manual / Auto enable
12	Pendant enable switch
13	Lamp control circuit with burnout detection
14	Front panel
15	High power ON / OFF
16	eV+ High power request
17	Auto 2
18	Auto 1
19	Manual 2
20	Manual 1
21	High power request
22	User E-Stop and gate interlock (jumper closed when not in use, must open both channels independently if used)
23	User E-Stop indication
24	Line E-Stop (external user E-Stop system)
25	User manual / auto indication (manual = open)
26	Muted safety gate - active in auto mode only (jumper closed when not used)
27	Connections at robot or module system (no user connections)

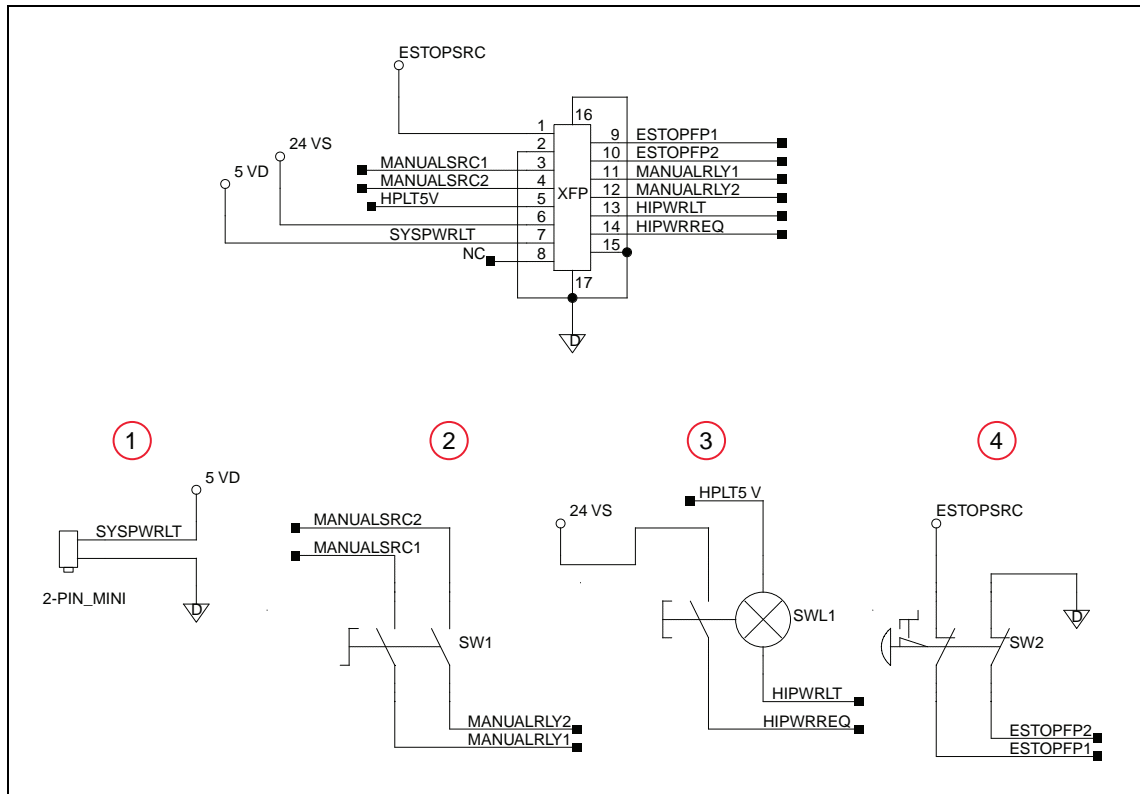

Figure 4-4. Front Panel Schematic

Table 4-11. Front Panel Schematic Descriptions

Item	Description
1	System power LED
2	Manual / Auto
3	High power ON / OFF
4	Emergency stop

Emergency Stop Circuits

The SmartController EX motion controller provides connections for Emergency Stop (E-Stop) circuits on the XUSR and XFP connectors. This gives the controller system the ability to duplicate E-Stop functionality from a remote location using voltage-free contacts. See the figure CAT-3 E-Stop Circuit on XUSR and XFP Connectors on page 39.

The XUSR connector provides external two-channel E-Stop input on pin pairs 1, 14 and 2, 15. The XFP connector provides two-channel E-Stop input on pin pairs 1, 9 and 2, 10.

NOTE: These pins must be shorted if not used. Both channels must open independently if used. Although an Emergency Stop will occur, the controller will flag an error state if one channel is jumpered closed and the other channel is opened. It will also flag an error state if the channels are shorted together.

User E-Stop Indication Contacts - Remote Sensing of E-Stop

These contacts provide a method to indicate the status of the ESTOP chain, inclusive of the Front Panel Emergency Stop push-button, the pendant Emergency Stop push-button, and the User Emergency Stop Contacts.

NOTE: These contacts do not indicate the status of any connections below the User E-Stop contacts. Thus, they will NOT indicate the status of the Line E-Stop, MCP ENABLE, or the Muted Safety gate. If you have a specific need in this area, contact your sales representative for information on alternate indicating modes.

Two pairs of pins on the XUSR connector (pins 7, 20 and 8, 21) provide voltage-free contacts, one for each channel, to indicate whether the E-Stop chain, as described above, on that channel is closed. Both switches are closed on each of the redundant circuits in normal operation (no E-Stop). The user may use these contacts to generate an E-Stop for other equipment in the workcell. The load on the contacts must not exceed 40 VDC or 30 VAC at a maximum of 1 A.

These voltage-free contacts are provided by a redundant, cyclically-checked, positive-drive, safety relay circuit for Category 3 PL-d per EN ISO 13849 operation (see the figure CAT-3 E-Stop Circuit on XUSR and XFP Connectors on page 39 and the table Contacts Provided by the XFP Connector on page 37 for the customer E-Stop circuitry).

Line E-Stop Input

The XUSR connector on the controller contains a two-channel Line E-Stop input for workcell or other equipment emergency-stop inputs. Generally, the customer E-Stop Indication contact outputs are used to generate an emergency stop in such external equipment. Thus, if one were to wire the same equipment's outputs into the customer E-Stop input (that is, in series with the local robot's E-Stop push-buttons), a lock-up situation could occur.

The Line E-Stop input comes into the circuit at a point where it cannot affect the customer E-Stop indication relays and will not cause such a lock-up situation. For any situation where two systems should be cross-coupled, for example, the customer E-Stop indication of one controller is to be connected to the input of another controller, the Line E-Stop input is the point to bring in the other controller's output contacts. See the figure CAT-3 E-Stop Circuit on XUSR and XFP Connectors on page 39 for more information.

Do not use the Line E-Stop for such devices as local E-Stop push-buttons, since their status should be reported to the outside on the local user E-Stop indication output contact while the Line E-Stop inputs will not.

Muted Safety Gate E-Stop Circuitry

Two pairs of pins on the XUSR connector (pins 5, 18 and 6, 19) provide connections for a safety gate designed to yield an E-Stop allowing access to the workspace of the robot in Manual mode only, not in Automatic mode. It is up to the customer to determine if teaching the robot in Manual Mode, by a skilled programmer (See Qualification of Personnel in the Robot Safety Guide), wearing safety equipment and carrying a pendant, is allowable under local regulations. The E-Stop is said to be "muted" in Manual mode (for the customer E-Stop circuitry, see the figures and tables at the beginning of the section Connecting User-Supplied Safety and Power-Control Equipment on page 35).

The muted capability is useful for a situation where a shutdown must occur if the cell gate is opened in Automatic mode, but you need to open the gate in Manual mode. If the mute gate is opened in Automatic mode, the robot defaults to Manual mode operation when power is re-

enabled. In muted mode, the gate can be left open for personnel to work in the robot cell. However, safety is maintained because of the speed restriction.



CAUTION: If you want the cell gate to always cause a robot shutdown, wire the gate switch contacts in series with the user E-Stop inputs. Do not wire the gate switch into the muted safety gate inputs.

Remote Manual Mode

The Front Panel provides for a Manual Mode circuit. See Remote High Power ON / OFF Control on page 43 and your robot manual for further details about the customer Remote Manual Mode circuitry.

The Front Panel, or the user-supplied panel, must be incorporated into the robot workcell to provide a “Single Point of Control” (the pendant) when the controller is placed in Manual mode. Certain workcell devices, such as PLCs or conveyors, may need to be turned off when the operating mode switch is set to Manual mode. This is to ensure that the robot controller does not receive commands from devices other than from the pendant, the single point of control.

If the user needs to control the Manual / Automatic mode selection from other control equipment, then a custom splitter cable or complete replacement of the standard Front Panel may be required. See Front Panel Schematic on page 41. In this situation, a pair of contacts should be wired *in series* with the Front Panel Manual / Automatic mode contacts. Thus, both the Front Panel and the customer contacts need to be closed to allow Automatic mode.



WARNING: Do not wire user-supplied Manual / Automatic contacts in parallel with the factory Front Panel switch contact. This would violate the “Single Point of Control” principle and might allow Automatic (high-speed) mode to be selected while an operator is in the cell.

User Manual / Auto Indication

Two pairs of pins on the XUSR connector (pins 9, 22 and 10, 23) provide a voltage-free contact to indicate whether the Front Panel and / or remote Manual / Automatic switches are closed. The user may use these contacts to control other mechanisms (for example, conveyor, linear modules, etc.) when Manual mode is selected. The load on the contacts should not exceed 40 VDC or 30 VAC at a maximum of 1 A.

User High Power On Indication

In the SmartController EX motion controller, eV+ controls a normally-open relay contact on the XDIO connector (pins 45, 46, see the table XDIO Digital I/O Connector Pin Assignments on page 50), that will close when high power has been enabled. The user can use this feature to power an indicator lamp or other device, that signals High Power is On. The limit on these contacts is 1 A at 30 VDC or 30 VAC.

Remote High Power ON / OFF Control

The easiest and most effective way to provide the high power ON / OFF control in a remote location is to mount the Front Panel in the desired location with an extension cable.

However, if the user needs to control high power ON / OFF from other control equipment or from a location other than the Front Panel, then a custom splitter cable will be required. See the Front Panel schematic (Front Panel Schematic on page 41) for details of the Front Panel's wiring. In this situation, a second momentary contact for high power ON / OFF would be placed *in parallel with* the Front Panel push-button contact. This second contact should be suppressed when in Manual mode (see the note on "Single Point of Control" below).

This method allows relocating the push-button switch to a more convenient location. Implementation of this method must conform to EN standard recommendations.

NOTE: European standards require that the remote High Power push-button be located outside of the workspace of the robot.

Pins 6, 14 and 5, 13 of the XFP connector provide this remote capability. Pins 5, 13 provide power for the lamp, +5 VDC and ground, respectively. Pins 6, 14 are inputs for voltage-free normally-open contacts from a user-supplied momentary push-button switch.



WARNING: To fulfill the "Single Point of Control" requirement, do not place the Manual / Automatic and High Power On controls in multiple locations. After putting the robot into Manual mode, the operator should remove the key for safety purposes. The system should not be wired so that a PLC or another operator can put the system back into Automatic mode.

High Power ON / OFF Lamp

The Front Panel High Power ON / OFF Lamp (P/N: 27400-29006) will cause an error, from eV+, if the lamp burns out. This error prevents High Power from being turned on. This safety feature prevents a user from not realizing that High Power is enabled because the High Power indicator is burned out.

Remote Front Panel or User-Supplied Control Panel Usage

Users can mount the Front Panel remotely by using an extension cable or by wiring a user-supplied Front Panel (control panel) to the controller using the 15-pin XFP connector. The Front Panel contains no active components, only switches and lights. Customers should be able to adapt the Front Panel's functionality into their own Front Panel design. To automatically control the Front Panel's signals, use relay contacts instead of switches. See the figure Front Panel Schematic on page 41 for a schematic drawing of the Front Panel, and see the table Contacts Provided by the XFP Connector on page 37 for a summary of connections and pin numbers.

NOTE: The system was evaluated by Underwriters Laboratory with a factory Front Panel. If you provide a substitute Front Panel, the system may no longer be UL compliant.

Customers can build an extension cable to place the Front Panel in a remote location. The extension cable must conform to the following specifications:

- Wire Size: must be larger than 26 AWG.
- Connectors: must be 15-pin, standard D-sub male and female.
- Maximum cable length is 10 meters.

NOTE: The XMCP and XFP connectors on the controller can be interchanged without electrical damage. However, neither the Front Panel nor the pendant will work properly unless they are plugged into the correct connector.

Remote Pendant Usage

Customers can build an extension cable to place the pendant in a remote location. The extension cable must conform to the following specifications:

- Wire Size: must be larger than 26 AWG.
- Connectors: must be 15-pin, standard D-sub male and female.
- Maximum cable length is 10 meters.



CAUTION: Do not modify the cable that is attached to the pendant. This could cause unpredictable behavior from the robot system.

4.6 Connecting User-Supplied Digital I/O Equipment

The controller contains two options for connecting Inputs and Outputs (I/O). I/O can be hard-wired to the XDIO and / or DeviceNet connectors.

DeviceNet Connector

The DeviceNet connector on the controller is used to interface to a CAN using the DeviceNet protocol. See DeviceNet on page 59 for details.

XDIO Connector

The XDIO connector on the SmartController EX motion controller is a 50-pin, standard density D-Sub female connector (see SmartController EX Connectors and Indicators on page 27 for location). There are 12 inputs and 8 outputs, each optically isolated from the circuitry of the controller. The signals are numbered 1001 through 1012 for the inputs and 1 through 8 for the outputs. All the signals have independent source and ground connections. These inputs contain the four high-speed inputs that are used by the system for interrupts and latching. The outputs, although independent, have a current rating of 100 mA. See the eV+ Language User's Guide for information on digital I/O programming.

The connector also provides 24 V pins for powering customer equipment. There are four 24 V pins and four ground pins, which are limited to a total of 1 A of current. The source of the 24 V is the XDC connector on the front of the controller.

Input Signals

The XDIO connector handles input signals 1001 to 1012. Each channel has an input and a corresponding return line. See the following table for input specifications. The connector pin-outs are shown in the table XDIO Digital I/O Connector Pin Assignments on page 50.

Table 4-12. Digital I/O Input Circuit Specifications (XDIO connector)

Operational voltage range	0 to 30 VDC
OFF state voltage range	0 to 3 VDC
ON state voltage range	10 to 30 VDC
Typical threshold voltage	$V_{in} = 8$ VDC
Operational current range	0 to 7.5 mA
OFF state current range	0 to 0.5 mA
ON state current range	2.5 to 7.5 mA
Typical threshold current	2.0 mA
Impedance (V_{in}/I_{in})	3.9 K Ω minimum
Current at $V_{in} = +24$ VDC	$I_{in} \leq 6$ mA
Turn-on response time (hardware) Software scan rate / response time	5 μ sec maximum 1 ms scan cycle/ 1 ms max response time
Turn-off response time (hardware) Software scan rate / response time	5 μ sec maximum 1 ms scan cycle/ 1 ms max response time

NOTE: The input current specifications are provided for reference; voltage sources are typically used to drive the inputs.

NOTE: When the program task priorities are properly set, there is a 1 ms maximum latency for the fast inputs when used with the eV+ INT.EVENT instruction.

The following figure shows inputs 1001 to 1004 with a negative common, inputs 1005 to 1008 with a positive common, and inputs 1009 to 1012 with independent power supply connections (no common).

NOTE: These are examples. Either method can be used on any channel.

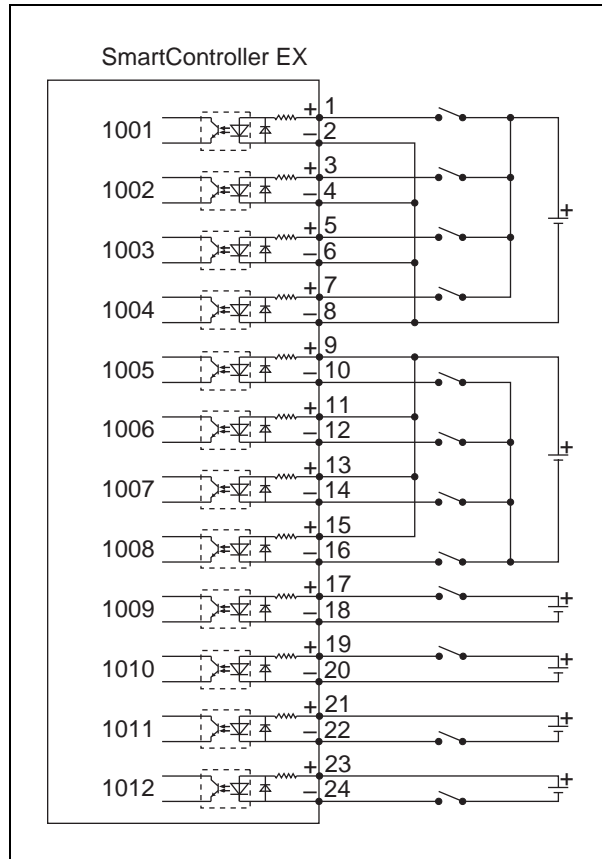

Figure 4-5. Digital Input Wiring Examples for XDIO Connector

NOTE: Power from pins 41-44 and 47-50 can be substituted for the input signal power supply. See the figure Digital Output Wiring Examples for XDIO Connector on page 49 and the table Digital I/O Input Circuit Specifications (XDIO connector) on page 46 for additional information.

REACT Input Signals 1001 to 1012

Inputs 1001 to 1012 (only) may be used by the eV+ REACT and REACTI instructions. See the eV+ Language Reference Guide for information on these instructions. If you are going to use these instructions, you should plan your digital I/O channel usage accordingly.

In addition to functioning as normal input signals, all input signals can have the following special uses:

- Fast DIO eV+ Interrupt Events (INT.EVENT)
- Robot and Encoder Position Latch

Fast DIO interrupt events (using INT.EVENT) require the optional eV+ Extensions License. When the program task priorities are properly set, there is a 1 ms maximum latency for the fast inputs when used with the eV+ INT.EVENT instruction.

See the eV+ Language Reference Guide for a description of the INT.EVENT instruction.

Output Signals

The XDIO connector handles output signals 0001 to 0008. Refer to the following table for output specifications. The locations of the signals on the connector are shown in the table XDIO Digital I/O Connector Pin Assignments on page 50. The XDIO connector provides separate positive and negative connections for each channel (no internal common connections). This allows the choice of wiring for current-sourcing or current-sinking modes.

Table 4-13. DIO Output Specifications (XDIO connector)

Operating voltage range	0 to 24 VDC
Operational current range, per channel	$I_{out} \leq 100$ mA, short-circuit protected, 1 A total at 24 V
V drop across output in ON condition	$V_{drop} \leq 2.7$ V at 100 mA $V_{drop} \leq 2.0$ V at 10 mA
Output off leakage current	$I_{out} \leq 600$ μ A
Turn-on response time (hardware) Software scan rate / response time	3 μ sec maximum 1 ms scan cycle 1 ms max. response time
Turn-off response time (hardware) Software scan rate / response time	200 μ sec maximum 1 ms scan cycle 1 ms max. response time

The following figure shows two examples of different connections to the digital outputs on the XDIO connector. The examples are negative common and positive common using the internal 24 V and ground connections.

Outputs 0001 to 0004 are shown with a positive common. Outputs 0005 to 0008 are shown with a negative common.

NOTE: These are examples. Either method can be used, in any combination, on any channel. Also, an external customer-provided power supply could have been provided instead of the power provided on the XDIO connector.

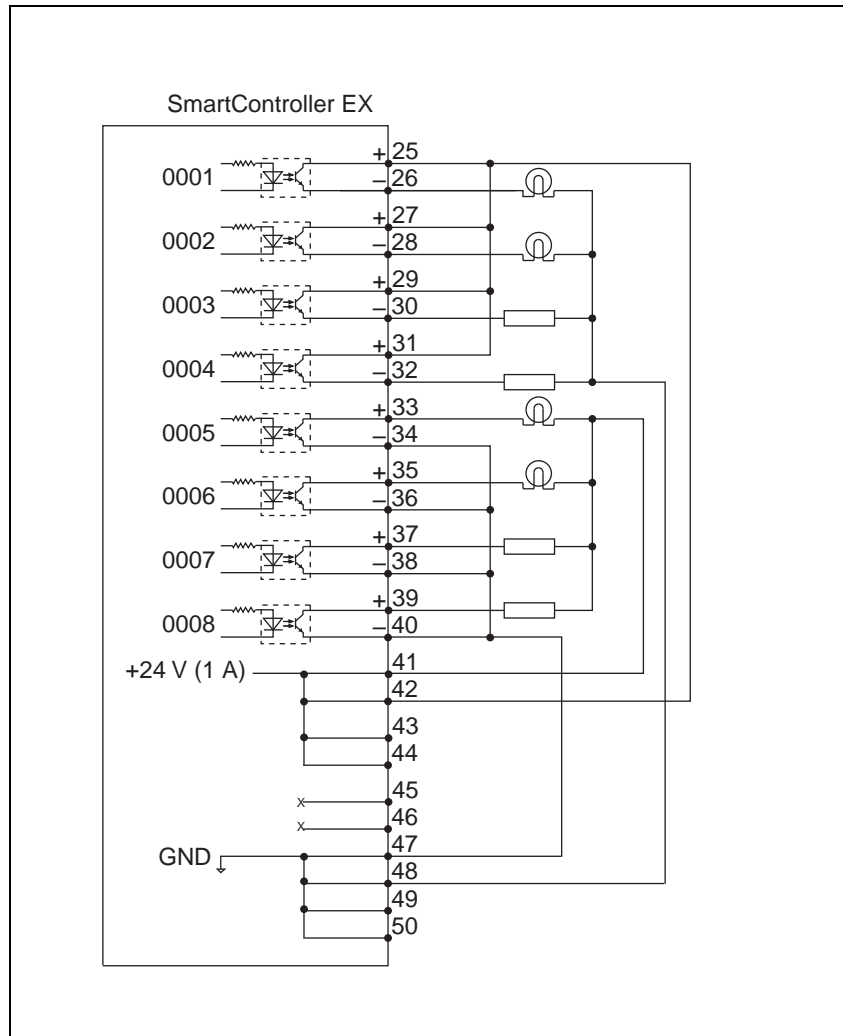

Figure 4-6. Digital Output Wiring Examples for XDIO Connector

Table 4-14. XDIO Digital I/O Connector Pin Assignments

Pin	Signal	Pin	Signal	Pin	Signal	Pin	Signal
1	Input 1001	2	1001 return	25	Output 0001+	26	Output 0001-
3	Input 1002	4	1002 return	27	Output 0002+	28	Output 0002-
5	Input 1003	6	1003 return	29	Output 0003+	30	Output 0003-
7	Input 1004	8	1004 return	31	Output 0004+	32	Output 0004-
9	Input 1005	10	1005 return	33	Output 0005+	34	Output 0005-
11	Input 1006	12	1006 return	35	Output 0006+	36	Output 0006-
13	Input 1007	14	1007 return	37	Output 0007+	38	Output 0007-
15	Input 1008	16	1008 return	39	Output 0008+	40	Output 0008-
17	Input 1009	18	1009 return	41	24 V Output ^a	42	24 V Output ^a
19	Input 1010	20	1010 return	43	24 V Output ^a	44	24 V Output ^a
21	Input 1011	22	1011 return	45	eV+ High Power On Indicator +	46	eV+ High Power On Indicator -
23	Input 1012	24	1012 return	47	24 V return	48	24 V return
				49	24 V return	50	24 V return
<p>The diagram shows a top-down view of a 50-pin D-subminiature connector. The pins are arranged in two rows of 25 pins each. Specific pins are labeled: Pin 1 (top right), Pin 17 (top left), Pin 18 (bottom right), Pin 33 (bottom left), Pin 34 (bottom right), and Pin 50 (bottom left).</p>							
^a Limited to combined total of 1 A of current.							

Digital I/O Connectors (Third-Party Sources)

The XDIO connector on the controller is a 50-pin, standard-density D sub-miniature female socket. The user-supplied cable must terminate in a suitable 50-pin male D-sub plug. The plug is not supplied.

Compatible connectors are manufactured by TE Connectivity and by Norcomp. Contact your nearest TE Connectivity or Norcomp sales office to find your local distributor.

TE Connectivity Part Numbers for 50-Pin Male D-Sub

HDP-20 series D-Sub Connectors. Crimp snap-in contacts. Order item 1 (includes cover) or item 2 (no cover). Contact pins not included, order separately (item 3, quantity 50).

1. 1658661-1 Kit (Connector body, shield, enclosure, jackscrews)
2. 1658641-2 Connector body only

3. 66682-2 Contact Pin, Male, wire size 28-24 AWG (0.08-0.2 mm²)
(Pins also available for other wire sizes, contact TE Connectivity)

Norcomp Part Numbers for 50-Pin Male D-Sub

Norcomp 172 series solder cup D-Sub connectors.

- 172-E50-103R001

Screw-Terminal Field-Wiring Adapter Blocks

Several manufacturers make screw-terminal field-wiring blocks, usually DIN-rail mountable. These can be connected to the XDIO via a suitable shielded 50-pin cable (user-supplied).

Phoenix Contact Inc.

2315159 - VARIOFACE interface modules

Automation Systems Interconnect

11008 - IMDS series transition modules

4.7 Belt Encoder Interface

For use with conveyor tracking, the SmartController EX motion controller supports four independent external belt encoders through a 26-pin, female, D-sub connector. The pin assignments for the Belt Encoder connector are shown in the following table. See the figure Belt Encoder Typical Input Circuit on page 53 for a typical input circuit drawing.

NOTE: An adapter cable (09550-000) is available to split the 26-pin SmartController EX motion controller connector into two 15-pin connections, compatible with the legacy SmartController CX. The 15-pin adapter is P/N: 09443-000. Each 15-pin adapter provides two M12 connections.

All encoder inputs for the SmartController EX motion controller use a scheme similar to an RS-422 differential receiver based on industry standard 75175 integrated circuits. The difference is that a custom resistor network and two differential receivers are used on each of the A and B inputs. See the figure Belt Encoder Typical Input Circuit on page 53 for a schematic.

We strongly recommend using differential encoder outputs for maximum noise immunity. See the ACE User's Guide for more information on setting up and programming a conveyor-tracking application.

NOTE: Conveyor tracking requires the eV+ Extensions License, which can be obtained from your sales representative.

Table 4-15. Belt Encoder Connector Pin Assignments

Signal	Pin	Signal	Pin
Encoder 5 V Out	1	ENC2_B-	14
Encoder Ground	10	ENC3_B+	15
ENC1_A+	2	ENC3_B-	16
ENC1_A-	3	ENC4_B+	17
ENC2_A+	4	ENC4_B-	18
ENC2_A-	5	ENC1_Z+	19
ENC3_A+	6	ENC1_Z-	20
ENC3_A-	7	ENC2_Z+	21
ENC4_A+	8	ENC2_Z-	22
ENC4_A-	9	ENC3_Z+	23
ENC1_B+	11	ENC3_Z-	24
ENC1_B-	12	ENC4_Z+	25
ENC2_B+	13	ENC4_Z-	26

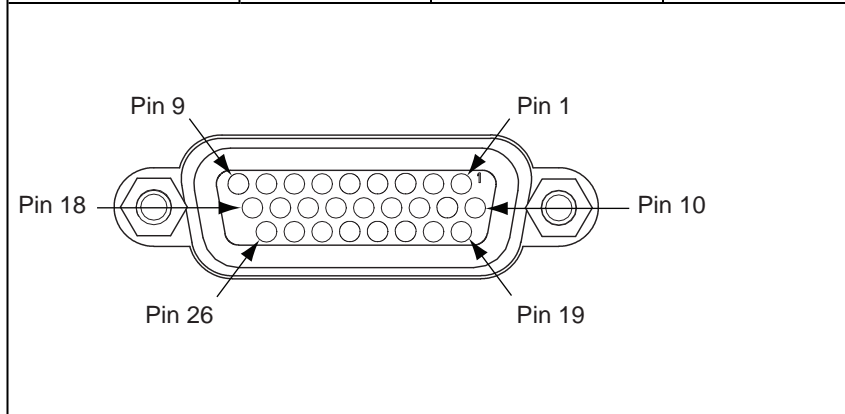

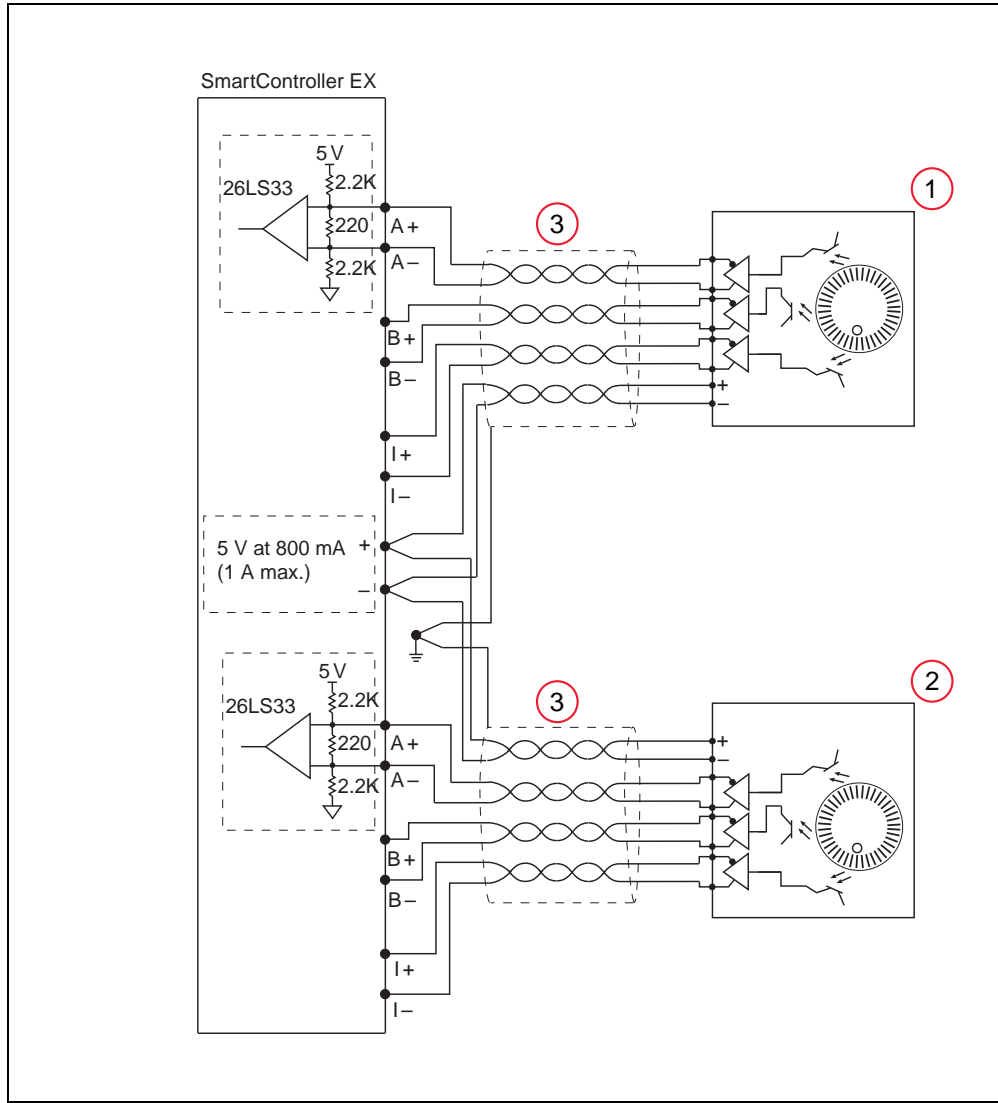

Figure 4-7. Belt Encoder Typical Input Circuit

Table 4-16. Belt Encoder Typical Input Descriptions

Item	Description
1	Encoder 1
2	Encoder 2
3	Shield

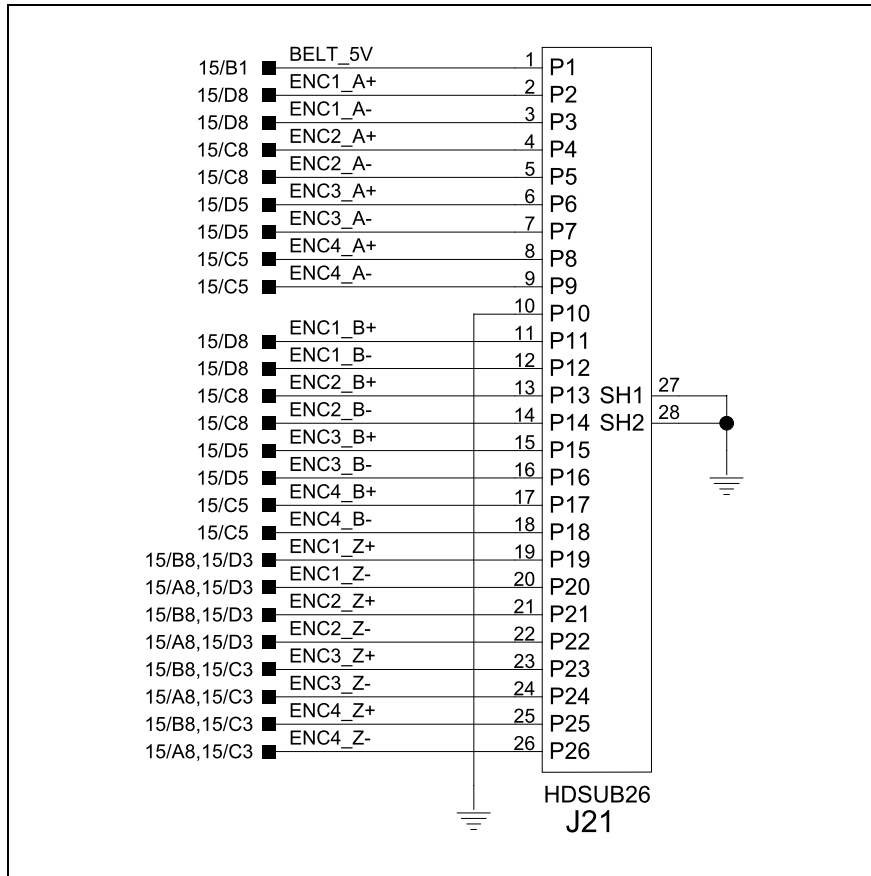

Figure 4-8. Belt Encoder Connector

Chapter 5: Technical Specifications

This chapter shows the dimensions of the SmartController EX motion controller, Front Panel, and T20 pendant.

5.1 SmartController EX Motion Controller Dimensions

NOTE: The dimensions for the legacy CS and CX SmartController motion controllers were the same as these.

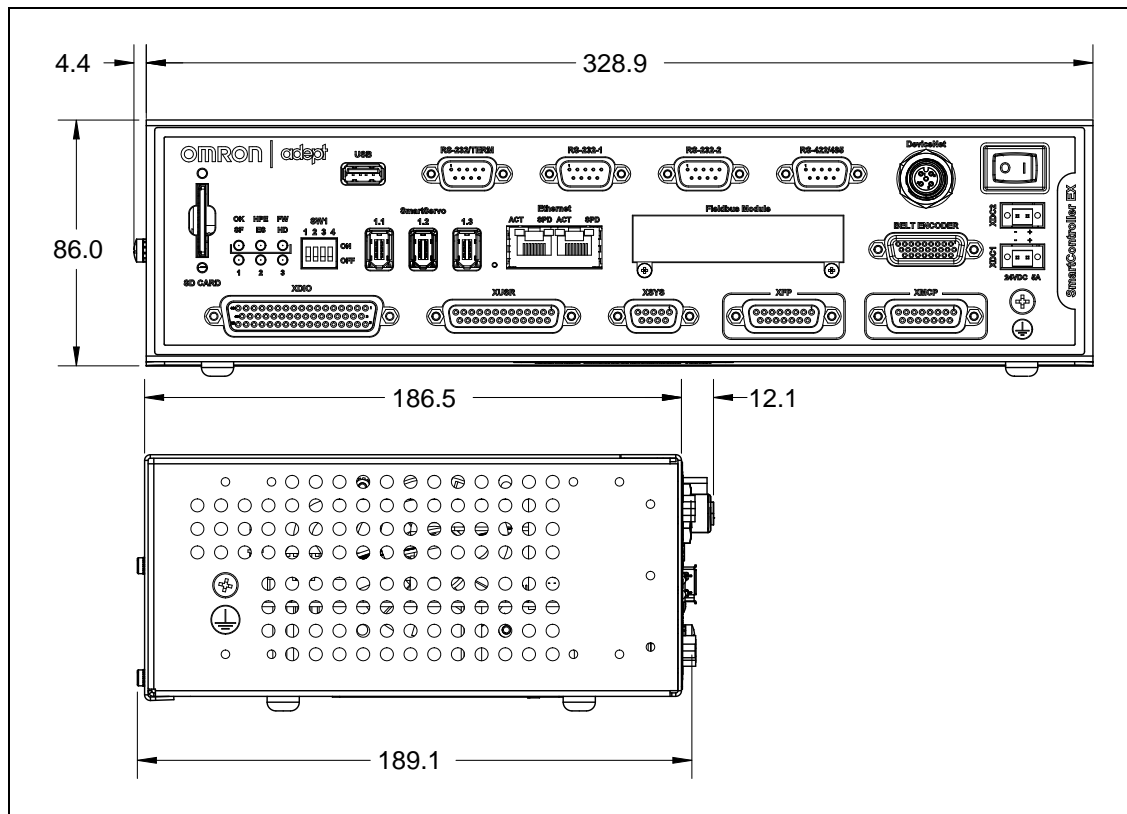

Figure 5-1. SmartController EX Motion Controller Dimensions (Units in mm)

5.2 Front Panel Dimensions

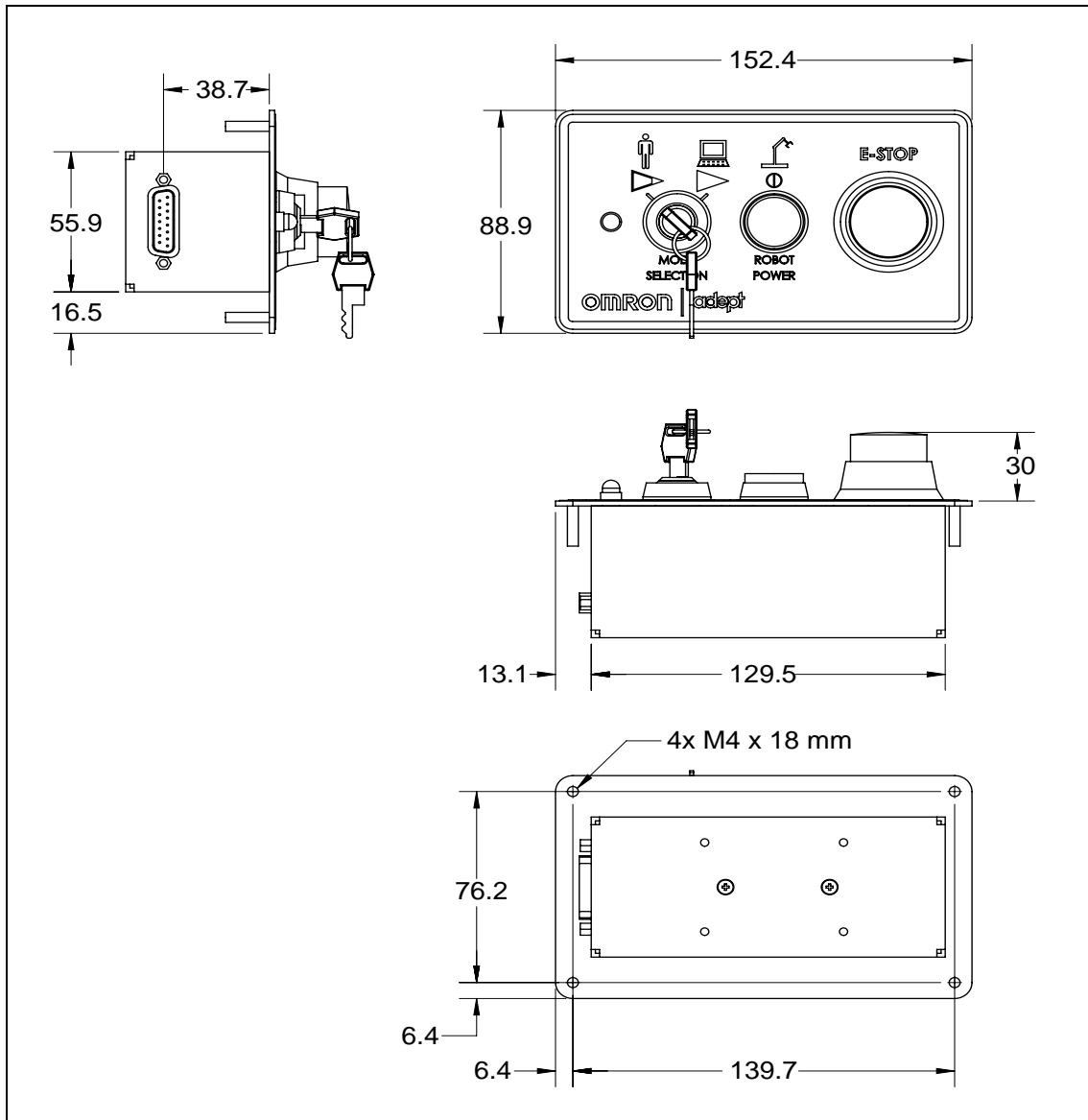

Figure 5-2. Front Panel Dimensions (Units in mm)

5.3 T20 Pendant Dimensions



Figure 5-3. T20 Pendant Dimensions (Units in mm)

Chapter 6: DeviceNet

DeviceNet is a low-cost communications link that connects industrial devices to a network and eliminates expensive hard-wiring. The direct connectivity provides improved communication between devices as well as important device-level diagnostics not easily available using hard-wired I/O interfaces.

6.1 DeviceNet Specifications

Omron Adept Technologies, Inc. is a member of the Open DeviceNet Vendor Association (ODVA), which is independently run and operated and not directly associated with any one company. The ODVA controls DeviceNet technical specifications with help from Special Interest Groups (SIGs). Each SIG develops device profiles for one line of product features to ensure interoperability. These profiles become part of the technical specifications.

The DeviceNet Specification is divided into two volumes and defines the following elements:

Volume 1

- DeviceNet Communication Protocol and Application (Layer 7 - Application Layer¹)
- Controller Area Network (CAN) and its use in DeviceNet (Layer 2 - Data Link Layer)
- DeviceNet Physical Layer and Media (Layer 1 - Physical Layer)

Volume 2

- Device profiles to obtain interoperability and interchangeability among like products

DeviceNet incorporates CAN, which defines the syntax or form of the data transmitted. The DeviceNet application layer defines the semantics or meaning of the data transmitted. For more information on the basics of a DeviceNet cable system, contact ODVA at:

ODVA Technology and Training Center
4220 Varsity Drive, Suite A
Ann Arbor, MI 48108-5006 USA
Phone Number: 1-734-975-8840
Fax Number: 1-734-922-0027
www.odva.org

¹These layers are based on the Open Systems Interconnect (OSI) model.

6.2 Limitations of the DeviceNet Scanner

The DeviceNet Scanner that is incorporated into the SmartController EX motion controller hardware and the eV+ operating system currently supports only a subset of full DeviceNet functionality. The following is a summary of this DeviceNet implementation:

- Implemented the *Master-Slave* operation. This is a complete subset of Peer-to-Peer operation.
- Implemented the *Unconnected Message Manager* (UCMM) in its DeviceNet Scanner to establish connections.

UCMM is used to establish *I/O Connections*.

- The DeviceNet Scanner can be a *Client* or a *Server* on the network.
- The DeviceNet Scanner currently does **not** support *Cyclic* or *Change-of-State* connections.
- Only *I/O Messaging* is supported. I/O messages contain only data.
- Currently, only the *Message Group 2* of the *Predefined Master / Slave Connection Set* is supported.
- Message Group 2 I/O connections support only the *I/O Poll Command / Response Message* of the possible message types.

6.3 DeviceNet Port on the Controller

The DeviceNet port on the SmartController EX motion controller has the following configuration:

Micro-style 12 mm thread DIN connector (female). See the following table for pin assignments.

Table 6-1. DeviceNet Signal-to-Pin Locations

Pin Number	Signal Name
1	Drain
2	V+
3	V-
4	CAN_H
5	CAN_L

See the figure Micro-Style DeviceNet Connector Pinouts (Viewed from Contact End) on page 69 for a drawing of the connectors.

Connecting DeviceNet Hardware to the Controller

To connect DeviceNet components to the controller, connect a drop line to the female Micro-style 12 mm-thread DIN connector on the front of the controller. Then you must configure the DeviceNet Scanner correctly using the ACE Configuration Tools.

NOTE: By default, the controller does not supply 24 V power to the DeviceNet bus. A separate power supply can be used to power the components on the DeviceNet bus, or the default can be overridden with jumpers. See Power Supply and the DeviceNet Bus on page 67.

NOTE: The controller incorporates a 120 Ohm line termination impedance. It is important that devices connected to the network also have a terminating resistor connected between CAN-H (white) and CAN-L (blue). See Termination of the DeviceNet Network on page 66.

Configuring DeviceNet

The SmartController EX motion controller has a default configuration such that, if you plug in a DeviceNet module configured with a baud rate of 125 kbps, the first 64 inputs and 64 outputs will automatically be mapped as the following signals:

MAC_ID 1

- Input: 1289 to 1352 and
- Output: 257 to 320

MAC_ID 2

- Input: 1353 to 1416 and
- Output: 321 to 384

This makes the DeviceNet plug and play.

For other configurations, use the ACE software for software setup. This assigns the controller signals to the physical ports of the DeviceNet nodes. Refer to the ACE User's Guide for details on configuring DeviceNet.

NOTE: The local setting baud rate must match the DeviceNet node's setting.

From the ACE software:

1. Double-click on the controller in the tree structure pane.
This will open the object editor for the controller.
2. Click the Configure button, check Configure DeviceNet, and click Next.
3. Follow the on-screen wizard instructions.

6.4 DeviceNet Physical Layer and Media

The DeviceNet physical layer and media specifications are published in the ODVA manual, chapter 9, volume 1. It describes possible topologies and components of the physical layer.

The figure Trunk Lines and Drop Lines Made of Thick and Thin Cable on page 62 shows several possible topologies. The DeviceNet specifications also specify system grounding, mixing of thick and thin cable media, termination, and power distribution.

The basic topology is the trunkline-dropline topology. This topology uses separate twisted-pair buses for the distribution of signals and power. The specifications allow trunk lines and drop

lines made of thick or thin cable. The baud rate, maximum distance from end-to-end of the network, and cable size are dependent on each other. See the table Features of a DeviceNet Network on page 63 for further details.

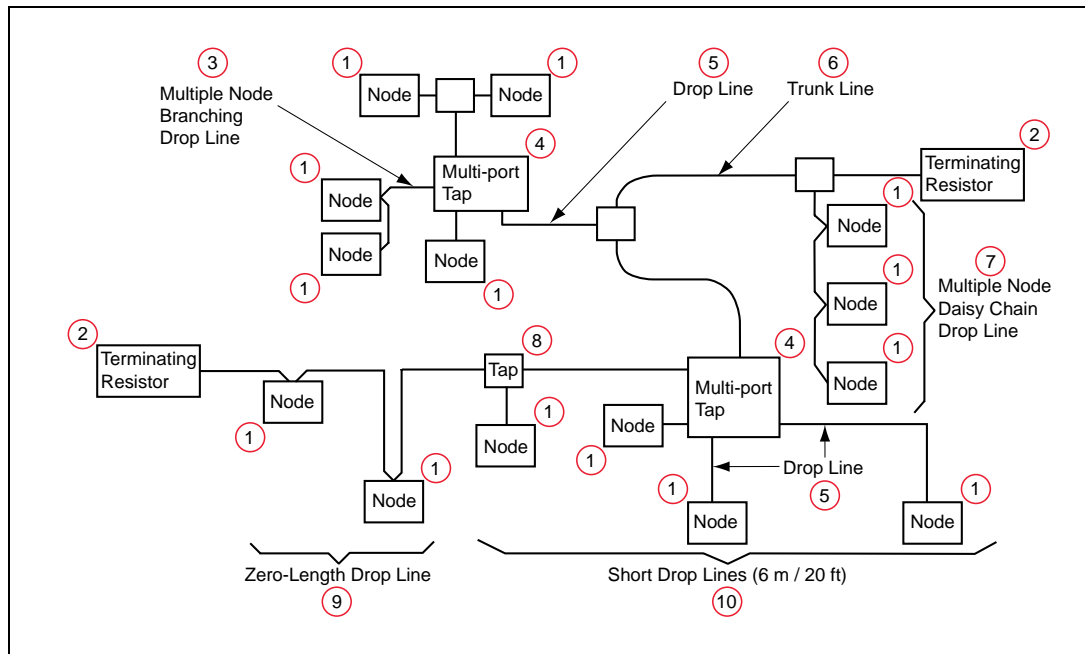

Figure 6-1. Trunk Lines and Drop Lines Made of Thick and Thin Cable

Table 6-2. Topology Description

Item	Description
1	Node
2	Terminating Resistor
3	Multiple Node Branching Drop Line
4	Multi-Port Tap
5	Drop Line
6	Trunk Line
7	Multiple Node Daisy Chain Drop Line
8	Tap
9	Zero-Length Drop Line
10	Short Drop Lines (6 m)

DeviceNet allows devices to be powered directly from the bus, and devices can use the same cable to communicate with other devices on the bus. DeviceNet nodes are hot-pluggable — you can remove or add components on the bus without powering down the network.

NOTE: This hot-pluggable feature requires the configuration of the controller to match the configuration of the physical network. The default configuration automatically recognizes and maps the first 64 bits of Mac ID 1 and 2. If the configuration needs to be changed, use ACE Configuration Tools.

The power distribution on the network / bus does not need to be in one place. The distribution of power supplies needs to be well-planned because there are certain constraints on the power supply. In general, power supplies can be placed at any point in the network. The maximum current rating of a trunk line is 8 amps. DeviceNet allows opto-isolated, externally powered devices (e.g., AC drive starters and solenoid valves) to operate on the same bus cable. For detailed information, see the DeviceNet Technical Specifications.

Table 6-3. Features of a DeviceNet Network

Network Size	A maximum of 64 nodes [0 - 63]
Network Length	Selectable, end-to-end network distance varies with speed
Data Packets	0-8 bytes
Bus Topology	Linear (trunk line / drop line); power and signal on the same network cable
Bus Addressing	Multi-Master and Master / Slave special case; polled

The baud rate of the system depends on the length of the network (end-to-end) and the type of cable. The following table shows how cable selection and trunk line length affect the maximum data rate on the network. The figure DeviceNet Thick Cable on page 64 shows a thick cable, and the figure DeviceNet Thin Cable on page 65 shows a thin cable.

Table 6-4. DeviceNet Data Rates Relative to Cable Type and Length

Data Rates	125 Kbps	250 Kbps	500 Kbps
Thick Trunk Length	500 m (1,640 ft)	250 m (820 ft)	100 m (328 ft)
Thin Trunk Length	100 m (328 ft)	100 m (328 ft)	100 m (328 ft)
Maximum Drop Length	6 m (20 ft)	6 m (20 ft)	6 m (20 ft)
Cumulative Drop Length	156 m (512 ft)	78 m (256 ft)	39 m (128 ft)

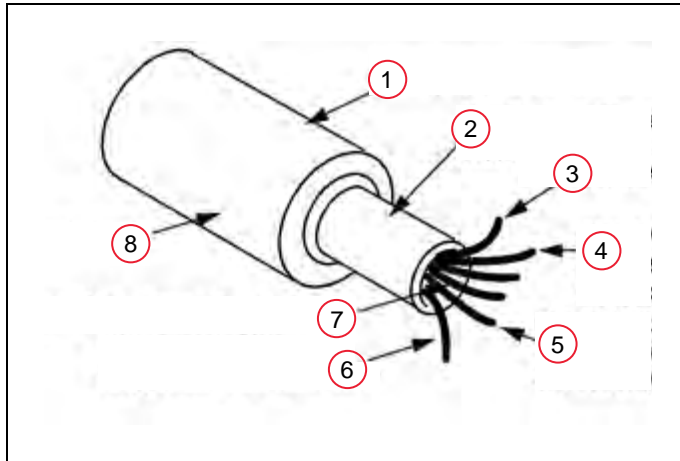

Figure 6-2. DeviceNet Thick Cable

Table 6-5. DeviceNet Thick Cable Descriptions

Item	Description
1	11 mm outside diameter
2	65% coverage tinned copper braid shield
3	Polypropylene fillers
4	Blue and white data-pair polyethylene (18 AWG 19 x 30 tinned copper conductors)
5	Red and black DC power pair PVC (15 AWG 19 x 28 tinned and stranded copper conductors)
6	18 AWS 19 x 30 tinned copper-stranded drain wire
7	Aluminum / mylar shield over each pair
8	External jacket

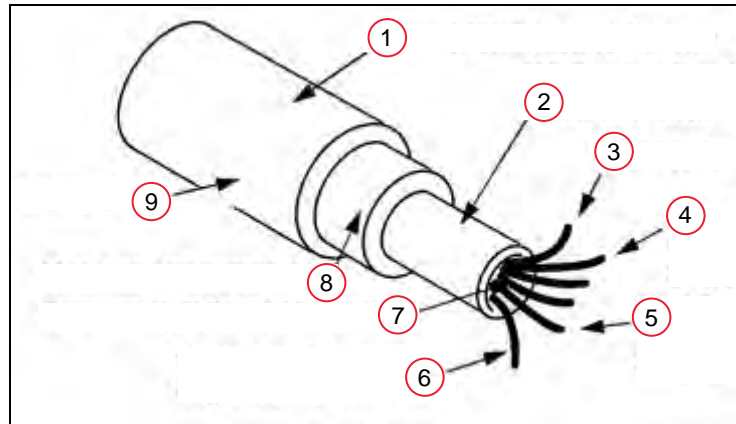

Figure 6-3. DeviceNet Thin Cable

Table 6-6. DeviceNet Thin Cable Descriptions

Item	Description
1	7.2 mm outside diameter
2	65% coverage tinned copper braided shield
3	Polypropylene fillers
4	Blue and white data-pair polyethylene (18 AWG 19 x 30 tinned copper conductors)
5	Red and black DC power pair PVC (15 AWG 19 x 28 tinned and stranded copper conductors)
6	18 AWG 19 x 30 tinned copper-stranded drain wire
7	Aluminum / mylar shield over each pair
8	Overall non-hydroscopic wrap
9	External jacket

DeviceNet Connectors

DeviceNet allows different connectors, which may be grouped into open and sealed connectors. The open connectors are available with screw or with crimp connectors. The sealed connectors are available in mini-style and micro-style sizes. See the following figure and table for more details.

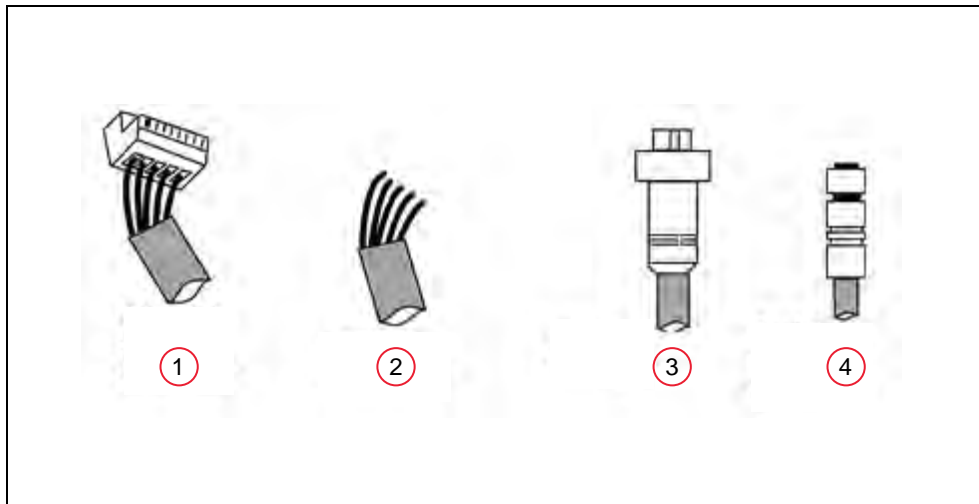

Figure 6-4. DeviceNet Connector Styles

Table 6-7. DeviceNet Connector Style Descriptions

Item	Connector Style	Description
1	Unsealed screw connector	Uses screws to attach wires to a removable connector
2	Unsealed hard-wired	Uses wires attached directly to screw terminals
3	Sealed mini-style	Attaches to taps and thick or thin cable
4	Sealed micro-style	Attaches to thin cable only – has a reduced current rating

Termination of the DeviceNet Network

The DeviceNet network uses the Controller Area Network (CAN) bus as the physical layer. This requires that the trunk line of your DeviceNet network be terminated with a resistor at each end. This terminates the signal lines.

The terminating resistor:

- Prevents reflection of communication signals on the network.
- Connects the two signal conductors.
- Must be sealed if the end node uses a sealed tee.
- Must be open if the end node uses an open-style tap.

The SmartController EX has a terminating resistor built-in, which can be used for one end of the DeviceNet network.

It is possible to disable this resistor by moving the JP2 jumper, which is internal to the SmartController EX. If you disable this resistor, a terminating resistor must then be used whenever a short drop line exceeds 6 m (20 ft). See the following figure.

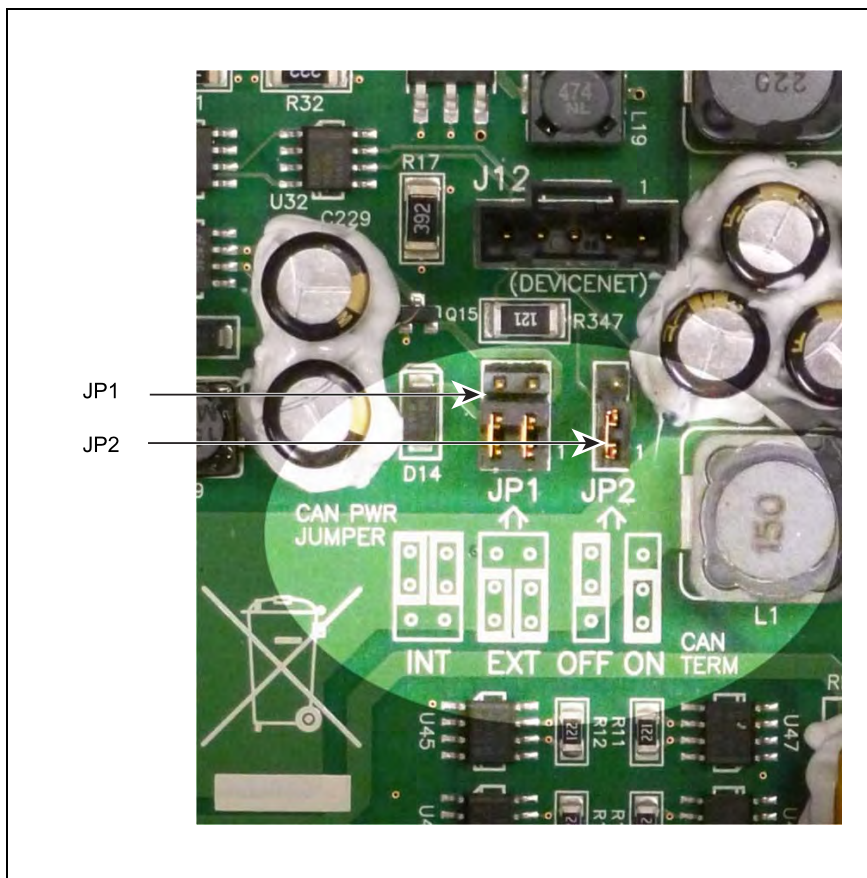

Figure 6-5. Internal CAN Power OFF, Terminating Resistor ON

NOTE: When using the open-style terminating resistor, connect a 121 ohm, $\frac{1}{4}$ W resistor to CAN_H and CAN_L (between blue and white data-pair wires).

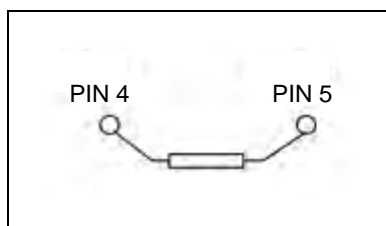

Figure 6-6. Example of a Terminating Resistor Installation on a DeviceNet Bus

Power Supply and the DeviceNet Bus

The DeviceNet network allows distribution of power supplies on the network cable system. Follow these general rules to achieve safe and reliable operation:

- Use power supplies rated at 24 V.
- Minimize installation problems by using a single power supply with sufficient current

to operate all the attached nodes. This must comply with national and international safety standards.

- Make sure that each power supply incorporates current-limit protection.
- Make sure each power supply is temperature-compensated.
- Provide over-current protection for each segment of your DeviceNet cable installation.

The SmartController EX CAN driver (CAN_H / CAN_L) is protected for shorts to the power terminals. The driver is protected for voltages in the range from -27 to +40 V.

By default, the 24 V supply for the DeviceNet bus on the SmartController is disabled.

If you do want the controller to supply 24 V, two jumpers need to be moved on JP1, on the SmartController board. To do this, move the jumpers from the EXT position to the INT position. See Figure 6-5.

- The jumpers provide an internal source of 24 V and GND from the EX controller for the CAN+CAN+ / CAN-- lines.
- Power is polyfuse-protected and can source 24 V (equal to controller V_{IN}) at up to 1.0 A.
- Power is diode-protected so it cannot back-drive the controller power.

Power Capabilities of a DeviceNet Cable System

A DeviceNet cable system has several power rating constraints. The cable type and the length of the cable affect the maximum current on a cable. Thick and thin cable have:

- 24 VDC power rating
- Optional power-supply tabs

If the power supplies are equipped with Schottky diodes, the optional power supply tabs must be protected from bus back-feeding of current among the power supplies on the bus. We also recommend the use of fuse protection for every trunk line in the cable system.

The maximum current rating of a thick cable trunk line is 8 A. Verify that this complies with your national and international standards. It might be necessary to limit the maximum current to a lower value if standards in the U.S. or Canada apply. The maximum current value is a theoretical value. The cable size supports a higher current than 8 A. Depending on the topology of nodes relative to the power supply, higher currents might be possible. See the DeviceNet technical specifications for further information.

The maximum current rating of a thin cable trunk line is 3 A. If you use the thin cable on a long line, the resistance of the cable decreases the maximum current value. See the following table and the DeviceNet technical specifications for further information.

Table 6-8. Maximum Current on a Drop Line Relative to its Length

Length of Drop Line	Maximum Current
1.5 m (5 ft)	3 A
2.0 m (6.6 ft)	2 A
3.3 m (10 ft)	1.5 A

Length of Drop Line	Maximum Current
4.5 m (15 ft)	1 A
6 m (20 ft)	0.75 A

For the calculation of the maximum current at a specific length, use the following formula:

$$i = \frac{4.57}{l}$$

Where:

l = Length of the drop line in meters (m)

i = Maximum current in amps

This calculation applies to the sum of the currents of all the nodes on the selected drop line. The length (l) is not the cumulative length of the drop line; it is the maximum distance from any node on the drop line to the trunk line.

It is important to note that voltage differences between the V- and V+ conductors need to be between 11 V and 25 V. The common-mode voltage between any two places on the V- wire must not exceed 5 V.

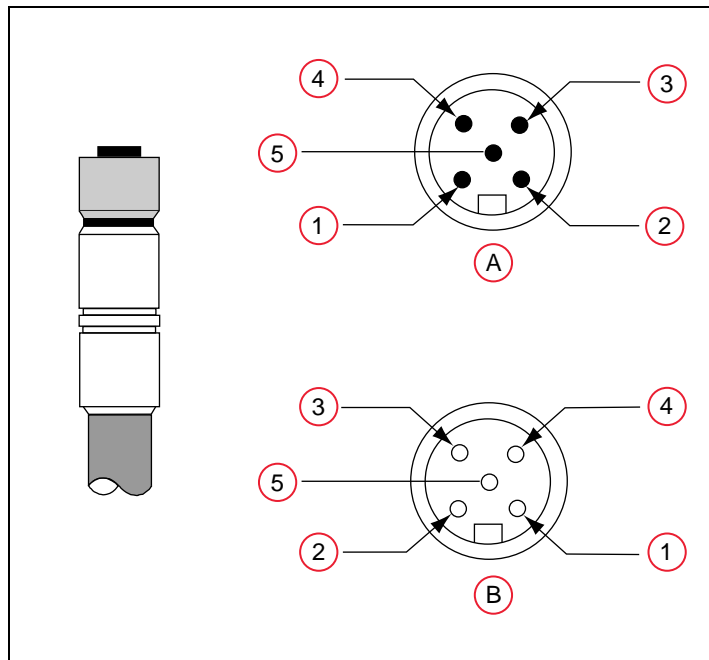

Figure 6-7. Micro-Style DeviceNet Connector Pinouts (Viewed from Contact End)

Table 6-9. Micro-Style DeviceNet Connector Pinout Legend

Item	Description
A	Male Connector (pins)
B	Female Connector (sockets)
1	Drain (bare)
2	V+ (red)
3	V- (black)
4	CAN_H (white)
5	CAN_L (blue)

OMRON Corporation Industrial Automation Company
Kyoto, JAPAN

Contact: www.ia.omron.com

Regional Headquarters

OMRON EUROPE B.V.

Wegalaan 67-69, 2132 JD Hoofddorp
The Netherlands
Tel: (31)2356-81-300/Fax: (31)2356-81-388

OMRON ASIA PACIFIC PTE. LTD.

No. 438A Alexandra Road # 05-05/08 (Lobby 2),
Alexandra Technopark,
Singapore 119967
Tel: (65) 6835-3011/Fax: (65) 6835-2711

OMRON ELECTRONICS LLC

2895 Greenspoint Parkway, Suite 200 Hoffman Estates,
IL 60169 U.S.A.
Tel: (1) 847-843-7900/Fax: (1) 847-843-7787

OMRON ADEPT TECHNOLOGIES, INC.

4550 Norris Canyon Road, Suite 150, San Ramon, CA 94583 U.S.A.
Tel: (1) 925-245-3400/Fax: (1) 925-960-0590

OMRON (CHINA) CO., LTD.

Room 2211, Bank of China Tower, 200 Yin Cheng Zhong Road,
PuDong New Area, Shanghai, 200120, China
Tel: (86) 21-5037-2222/Fax: (86) 21-5037-2200

Authorized Distributor:

© OMRON Corporation 2019 All Rights Reserved.
In the interest of product improvement,
specifications are subject to change without notice.

Cat. No. I602-E-03

Printed in USA
0319 (0116)

11069-000 H