

Programmable Multi-Axis Controller

Startup Guide

for SSI/Mitutoyo/EnDat 2.1/2.2

Serial Encoder

CK5M-CPU

CK3M-CPU

CK3W-AX

**Startup
Guide**

NOTE

1. All rights reserved. No part of this publication may be reproduced, stored in a retrieval system, or transmitted, in any form, or by any means, mechanical, electronic, photocopying, recording, or otherwise, without the prior written permission of OMRON.
2. No patent liability is assumed with respect to the use of the information contained herein.
Moreover, because OMRON is constantly striving to improve its high-quality products, the information contained in this manual is subject to change without notice.
3. Every precaution has been taken in the preparation of this manual. Nevertheless, OMRON assumes no responsibility for errors or omissions.
Neither is any liability assumed for damages resulting from the use of the information contained in this publication.

Trademarks

- Microsoft, Windows, Excel, Visual Basic, and Microsoft Edge are either registered trademarks or trademarks of Microsoft Corporation in the United States and other countries.
- EtherCAT® is registered trademark and patented technology, licensed by Beckhoff Automation GmbH, Germany.

Other company names and product names in this document are the trademarks or registered trademarks of their respective companies.

Copyrights

- Microsoft product screen shots used with permission from Microsoft.
- This product incorporates certain third party software. The license and copyright information associated with this software is available at http://www.fa.omron.co.jp/nj_info_e/.

Sections in this Manual

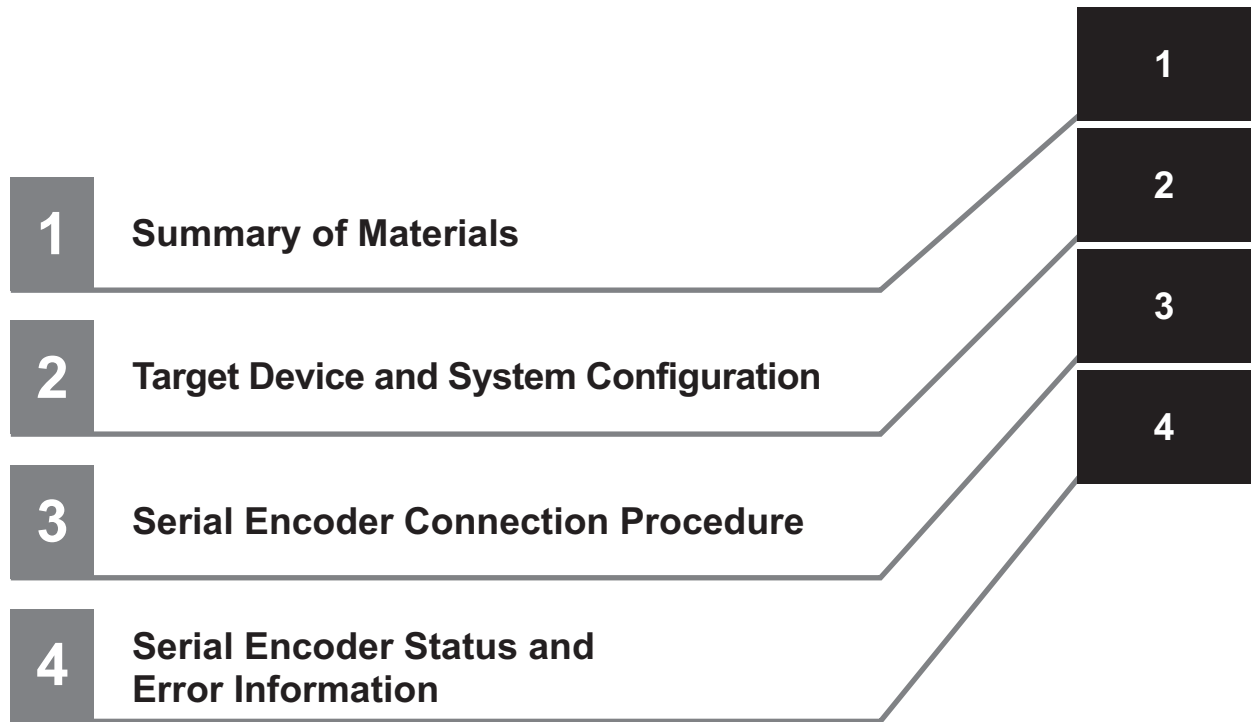

CONTENTS

Sections in this Manual	3
Precautions	5
Related Manuals.....	6
Terms and Definitions.....	7
Revision History.....	8

Section 1 About This Guide

1-1 Introduction	1-2
1-1-1 Intended Audience	1-2

Section 2 Target Device and System Configuration

2-1 Device Configuration.....	2-2
--------------------------------------	------------

Section 3 Serial Encoder Connection Procedure

3-1 Work Flow.....	3-2
3-2 Controller Setting Preparations.....	3-3
3-2-1 Creation of a New Project	3-3
3-2-2 Controller Initial Setting	3-4
3-3 Various Serial Encoder Wiring.....	3-6
3-3-1 If Using SSI Encoder	3-6
3-3-2 If Using Mitutoyo Encoder	3-6
3-3-3 If Using EnDat 2.1/2.2 Encoder.....	3-7
3-4 Various Controller Settings and Checking Operation	3-8

Section 4 Serial Encoder Status and Error Information

4-1 SSI Encoder Error Information	4-2
4-2 Mitutoyo Encoder Status and Error Information.....	4-3
4-3 EnDat 2.1/2.2 Encoder Status and Error Information	4-4

Precautions

- For actual system construction, check the specifications for each device and piece of equipment that makes up the system, use a method with sufficient margin for ratings and performance, and adopt safety circuits and other safety measures to minimize risks even if a breakdown occurs.
- To safely utilize the system, obtain a manual or user's guide for each device and piece of equipment that makes up the system, confirm their content, including "Safety Precautions", "Precautions for Safe Use", and other precautions related to safety, and then proceed with use.
- The customer must check all regulations, laws, and rules that are applicable to the system themselves.
- Copying, duplication, or redistribution of part or all of these materials without the permission of OMRON Corporation is prohibited.
- The content listed in these materials may be changed without notice for purposes of improvement.

The marks used in these materials are defined as follows.



Precautions for Correct Use

Precautions on what to do and what not to do to ensure correct operation and performance.



Additional Information

Additional information to read as required.

This information is provided to increase understanding and make operation easier.

Related Manuals

To safely utilize the system, obtain a manual or user's guide for each device and piece of equipment, confirm their content, including "Safety Precautions", "Precautions for Safe Use", and other precautions related to safety, and then proceed with use.

The manuals for OMRON Corporation (hereafter, "OMRON") and Delta Tau Data Systems Inc. (hereafter "DT") are as shown below.

Manufacturer	Cat. No.	Model	Manual Name
OMRON	O036	CK5M-CPU□ CK3M-CPU□ CK3W-AX□	Programmable Multi-Axis Controller Hardware User's Manual
DT	O014	---	Power PMAC User's Manual
DT	O015	---	Power PMAC Software Reference Manual
DT	O016	---	Power PMAC IDE User's Manual

Terms and Definitions

Terms	Descriptions and Definitions
PMAC	This is the acronym for Programmable Multi-Axis Controller.
Power PMAC IDE	This is computer software that is used to configure the Motion Controller, create user programs, and perform monitoring.
Serial Encoder	This is an encoder that uses communications to perform data transfer.

Revision History

A manual revision code appears as a suffix to the catalog number on the front and back covers.

Cat. No.	R195-E1-02
-----------------	-------------------

↑
Revision code

Revision code	Revision date	Revised content
01	July 2018	Original production
02	January 2023	<ul style="list-style-type: none">• Revisions due to the addition of the CK5M-CPU1□1• Corrected mistakes.



About This Guide

This section describes the overview of this guide.

1-1	Introduction	1-2
1-1-1	Intended Audience	1-2

1-1 Introduction

This document describes the connecting procedure and confirmation for an OMRON Programmable Multi-Axis Controller CK□M-□□□□ (hereinafter referred to as "Controller") and a serial encoder of SSI, Mitutoyo, and EnDat 2.1/2.2 with serial communication protocols.

By understanding the setting content and setting procedure points described in *3-3 Various Serial Encoder Wiring* on page 3-6, the Controller can communicate with each Serial Encoder, and absolute position information can be received.

1-1-1 Intended Audience

This guide is intended for the following personnel, who must also have knowledge of electrical systems (electrical or the equivalent).

- Personnel in charge of introducing FA systems.
- Personnel in charge of designing FA systems.
- Personnel in charge of installing and maintaining FA systems.
- Personnel in charge of managing FA systems and facilities.

Also, this guide is intended for personnel who understand the contents described in the DT manual.

2

Target Device and System Configuration

This section describes the target devices and system configuration to be used for EtherNet/IP connection in this guide.

2-1	Device Configuration	2-2
-----	----------------------------	-----

2-1 Device Configuration

The configuration devices for reproducing the connection procedures in this document are shown below.

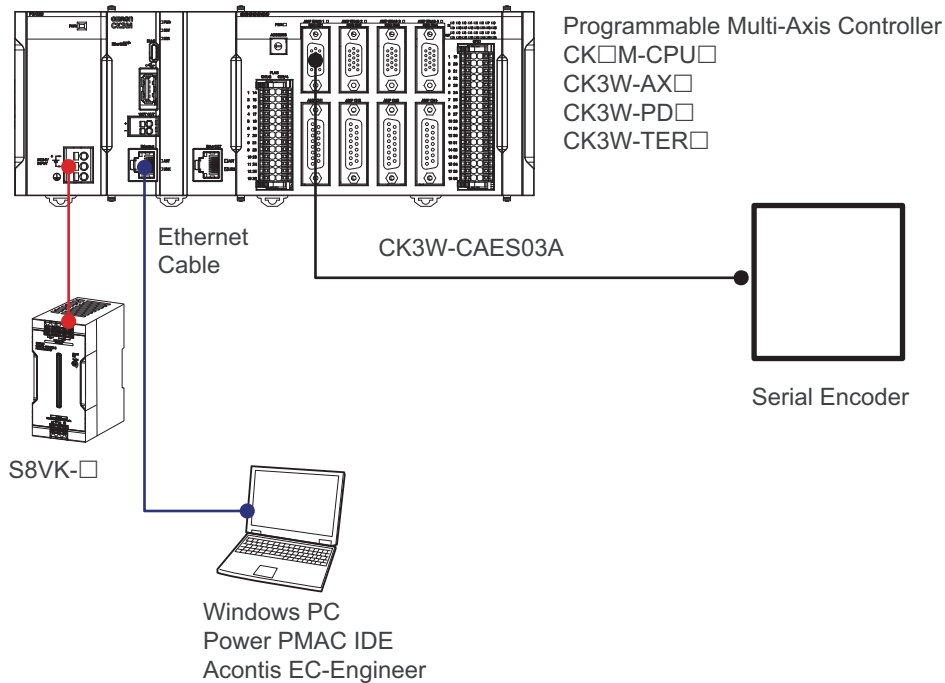

Manufacturer	Name	Model	Version
OMRON	Programmable Multi-Axis Controller CPU Unit	CK□M-CPU□	---
OMRON	Programmable Multi-Axis Controller Axis Interface Unit	CK3W-AX□	---
OMRON	Programmable Multi-Axis Controller Power Supply Unit	CK3W-PD□	---
OMRON	Programmable Multi-Axis Controller End Cover	CK3W-TER□	---
OMRON	Switch Mode Power Supply	S8VK-□	---
OMRON	Encoder Cable	CK3W-CAED03A	---
HEIDENHAIN	Serial Encoder (SSI)	ROQ425	---
Mitutoyo	Serial Encoder (Mitutoyo)	ST701A	---
HEIDENHAIN	Serial Encoder (EnDat 2.1/2.2)	ROQ437	---
---	Windows PC	---	---
DT	Power PMAC Setting Tool	Power PMAC IDE	4.0 or higher

3

Serial Encoder Connection Procedure

This section describes the procedures to connect the Controller and Serial Encoder. The description assumes that the Controller is set to factory default.

3-1	Work Flow	3-2
3-2	Controller Setting Preparations	3-3
3-2-1	Creation of a New Project	3-3
3-2-2	Controller Initial Setting	3-4
3-3	Various Serial Encoder Wiring	3-6
3-3-1	If Using SSI Encoder	3-6
3-3-2	If Using Mitutoyo Encoder	3-6
3-3-3	If Using EnDat 2.1/2.2 Encoder	3-7
3-4	Various Controller Settings and Checking Operation	3-8

3-1 Work Flow

The procedures for connecting the Controller and Serial Encoder are shown below.

3-2 Controller Setting Preparations on page 3-3	Perform the Controller setting preparations.
▼	
3-2-1 Creation of a New Project on page 3-3	
▼	
3-2-2 Controller Initial Setting on page 3-4	
▼	
3-3 Various Serial Encoder Wiring on page 3-6	Perform wiring for each device.
▼	
3-4 Various Controller Settings and Checking Operation on page 3-8	Perform the Controller settings and operation check.

3-2 Controller Setting Preparations

Perform the Controller setting preparations.
Install the Power PMAC IDE on the PC beforehand.

3-2-1 Creation of a New Project

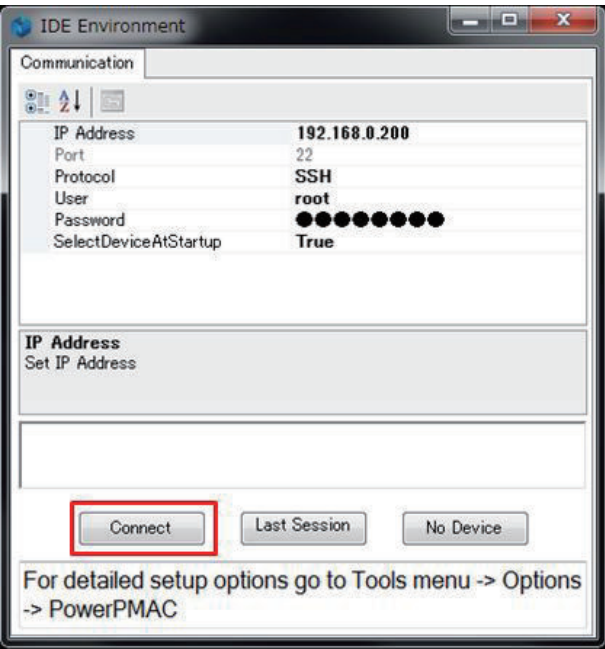
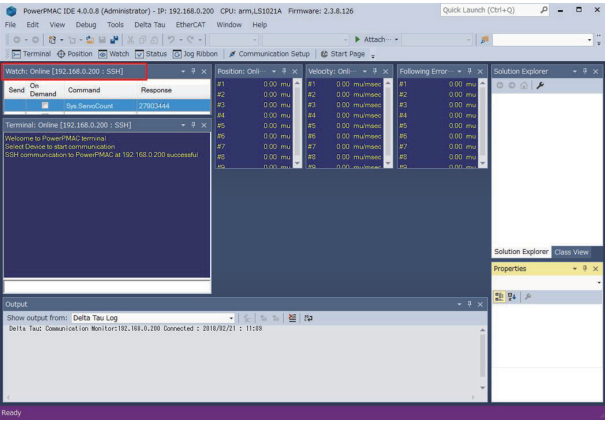
1	Connect the Controller and computer with an Ethernet cable.	
2	Turn ON the power supply to the Controller.	
3	Start up Power PMAC IDE. <ul style="list-style-type: none"> If a dialog for checking access rights is displayed at the time of startup, select the option for starting up. 	
4	The Communication screen is displayed, so specify the IP address of the Controller to be connected to, and click Connect . <ul style="list-style-type: none"> The default IP address for the Controller is 192.168.0.200. If necessary, change the Windows IP address to 192.168.0.X. 	
5	Power PMAC IDE starts up, and the Controller will come online.	

6 From the **File** menu, select **New, Project**.

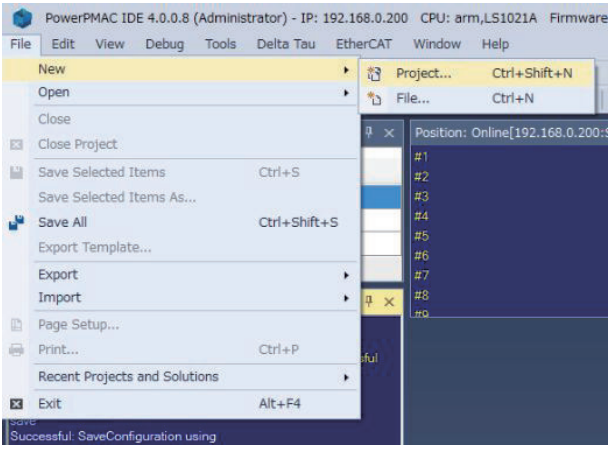

7 Input the desired project name and the save destination, and select **OK**.

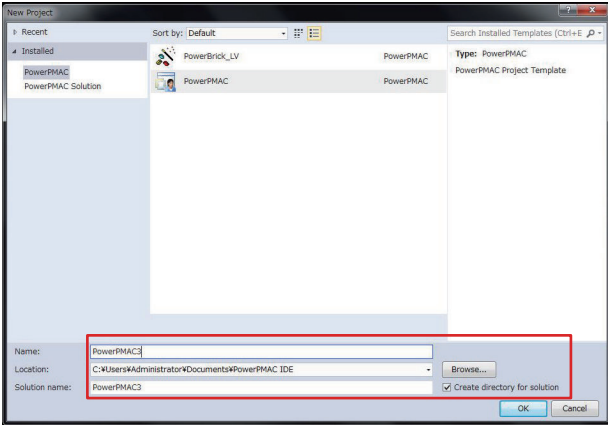

3-2-2 Controller Initial Setting

Perform the initial settings for the Controller.



Precautions for Correct Use

Since all memory is cleared by the initial settings, be sure to save any data remaining in the Controller that you may need.

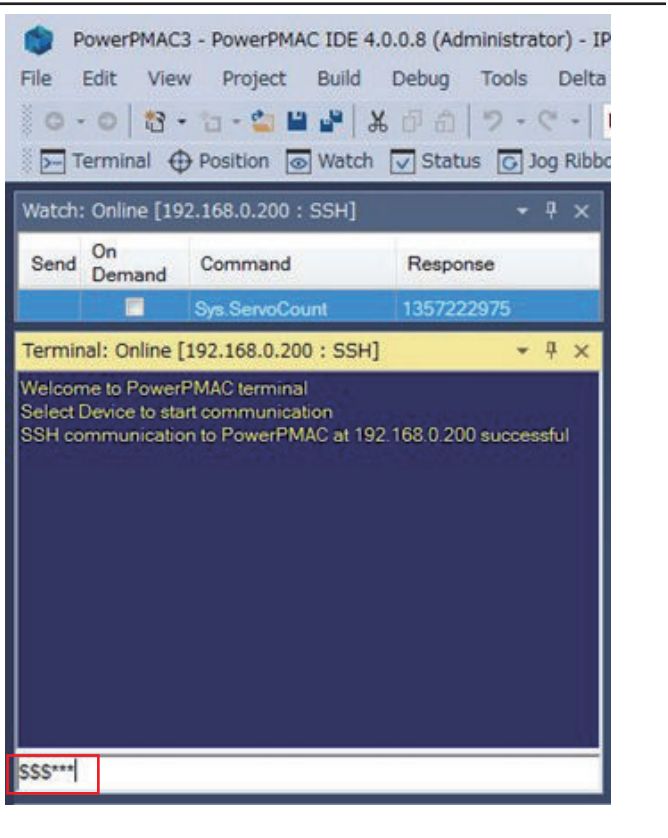
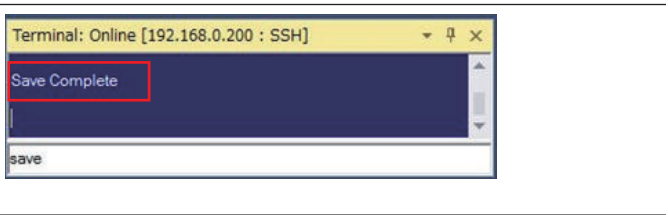
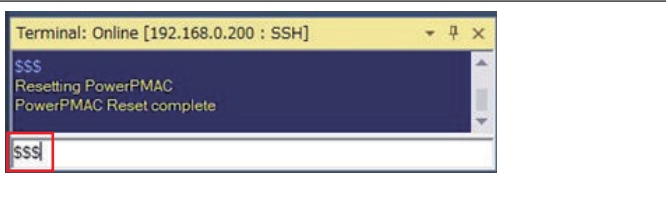
<p>1</p>	<p>Type the \$\$\$** command from the Terminal, and set the Controller to the factory default state.</p>	
<p>2</p>	<p>Type the save command in the Power PMAC IDE Terminal. When the save is completed, "Save Complete" is displayed in the Terminal.</p>	
<p>3</p>	<p>Type the \$\$\$ command in the Power PMAC IDE Terminal.</p>	

3-3 Various Serial Encoder Wiring

Perform wiring for the Axis Interface Unit and Serial Encoder in accordance with the wiring diagram below.

3-3-1 If Using SSI Encoder

CK3W-AX□

Encoder Connector

Signal	Pin No.
Serial Encoder DAT+	5
Serial Encoder DAT-	10
Serial Encoder CLK+	4
Serial Encoder CLK-	9
Encoder Power Supply (+5VDC)	12
Encoder Power Supply (GND)	14

SSI

Signal
DATA+
DATA-
CLOCK+
CLOCK-
5V
0V



Precautions for Correct Use

The maximum cable length changes depending on the data rate.
Use encoders within the following specification ranges.

Data rate	100 kbps	200 kbps	300 kbps	400 kbps	500 kbps	1.0 Mbps	1.5 Mbps	2.0 Mbps
Max. cable length	400 m	190 m	120 m	80 m	600 m	250 m	10 m	5 m

3-3-2 If Using Mitutoyo Encoder

Use an encoder that supports the Mitutoyo ENSIS interface.

Check the encoder vendor product specifications for the maximum cable length.

The following wiring example uses the *ST70X series*.

CK3W-AX□

Encoder Connector

Signal	Pin No.
Serial Encoder DAT+	5
Serial Encoder DAT-	10
Encoder Power Supply (+5VDC)	12
Encoder Power Supply (GND)	14

Mitutoyo

Signal
RQ/DT+
RQ/DT-
+5V/(VCC)
0V(GND)

3-3-3 If Using EnDat 2.1/2.2 Encoder

CK3W-AX□

Encoder Connector

Signal	Pin No.
Serial Encoder DAT+	5
Serial Encoder DAT-	10
Serial Encoder CLK+	4
Serial Encoder CLK-	9
Encoder Power Supply (+5VDC)	12
Encoder Power Supply (GND)	14

EnDat 2.1/2.2

Signal
DATA+
DATA-
CLOCK+
CLOCK-
5V
0V



Precautions for Correct Use

The maximum cable length changes depending on the data rate.
Use encoders within the following specification ranges.

Data rate	1.0 Mbps	2.0 Mbps	4.0 Mbps
Max. cable length	100 m	80 m	40 m

3-4 Various Controller Settings and Checking Operation

Perform the settings for connecting the Controller to the Serial Encoder.

1 Open Global Definitions.pmh under **PMAC Script Language — Global Includes** in the Solution Explorer.

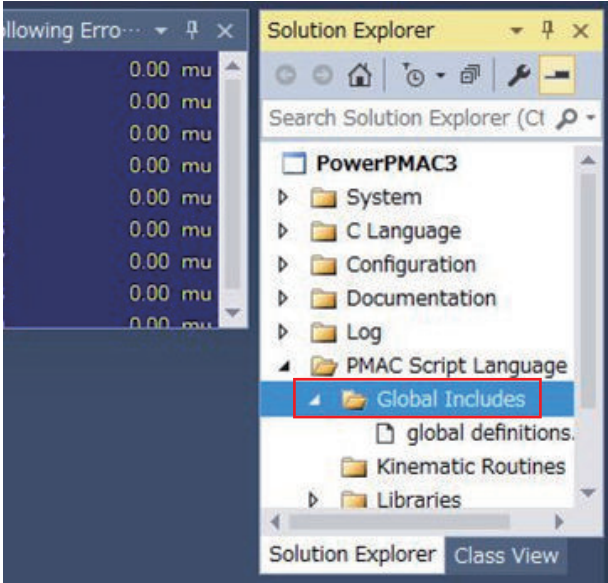

2

Write the text on the right to Global Definitions.pmh.

- For the following registers, perform settings according to the encoder specifications. For details on the registers, refer to DT's *Power PMAC Software Reference Manual (Cat. No. O015)*.
 - a) Gate3[i].SerialEncCtrl
 - b) Gate3[i].Chan[j].SerialEncCmd

- For SSI encoder with the following conditions

- a) 24 position bits
- b) No parity check
- c) Gray code format
- d) 2.0 Mbps (Maximum data rate is 2.0 Mbps)
- e) Trigger on the rising edge of servo clock (no delay)

```

Sys.WpKey = $AAAAAAAA //Release write-protect

```

```

//Setting phase frequency and servo frequency

```

```

Gate3[0].PhaseFreq = 32000

```

```

Gate3[0].ServoClockDiv = 3

```

```

Sys.ServoPeriod= 1/8

```

```

//Setting registers for Serial Encoder

```

```

Gate3[0].SerialEncCtrl = $31020002

```

```

Gate3[0].Chan[0].SerialEncCmd = $00001818

```

```

//Setting Encoder table

```

```

EncTable[1].type = 1

```

```

EncTable[1].pEnc = Gate3[0].Chan[0].SerialEncDataA.a

```

```

EncTable[1].ScaleFactor = 1

```

```

Motor[1].ServoCtrl = 1

```

```

Motor[1].pEnc = EncTable[1].a

```

```

Motor[1].pEnc2 = EncTable[1].a

```

```

//Enable Serial Encoder

```

```

Gate3[0].Chan[0].SerialEncEna = 1

```

- For Mitutoyo encoder with the following conditions
 - a) 2.5 Mbps (Maximum data rate is 2.5 Mbps)
 - b) Trigger on the rising edge of servo clock (no delay)

```
Sys.WpKey = $AAAAAAAA //Release write-protect

//Setting phase frequency and servo frequency
Gate3[0].PhaseFreq = 32000
Gate3[0].ServoClockDiv = 3
Sys.ServoPeriod= 1/8

//Setting registers for Serial Encoder
Gate3[0].SerialEncCtrl = $01020009
Gate3[0].Chan[0].SerialEncCmd = $00011000

//Setting Encoder table
EncTable[1].type = 1
EncTable[1].pEnc = Gate3[0].Chan[0].SerialEncDataA.a
EncTable[1].ScaleFactor = 1
Motor[1].ServoCtrl = 1
Motor[1].pEnc = EncTable[1].a
Motor[1].pEnc2 = EncTable[1].a

//Enable Serial Encoder
Gate3[0].Chan[0].SerialEncEna = 1
```

- For EnDat 2.1/2.2 encoder with the following conditions
 - a) 37 position bits
 - b) 2.0 Mbps (Maximum data rate is 4.0 Mbps)
 - c) Trigger on the rising edge of servo clock (no delay)
 - d) Perform delay compensation cycle at start up

```

Sys.WpKey = $AAAAAAAA //Release write-protect

```

```

//Setting phase frequency and servo frequency

```

```

Gate3[0].PhaseFreq = 32000

```

```

Gate3[0].ServoClockDiv = 3

```

```

Sys.ServoPeriod= 1/8

```

```

//Setting registers for Serial Encoder

```

```

Gate3[0].SerialEncCtrl = $01020003

```

```

//Setting Encoder table

```

```

EncTable[1].type = 1

```

```

EncTable[1].pEnc = Gate3[0].Chan[0].SerialEncDataA.a

```

```

EncTable[1].ScaleFactor = 1

```

```

Motor[1].ServoCtrl = 1

```

```

Motor[1].pEnc = EncTable[1].a

```

```

Motor[1].pEnc2 = EncTable[1].a

```

```

//Enable Serial Encoder

```

```

Gate3[0].Chan[0].SerialEncEna = 1

```

```

//Perform delay compensation cycle and position data reading

```

```

Gate3[0].Chan[0].SerialEncCmd = $80071025

```

3 If reading the absolute position at start-up, add the settings on the right to the bottom of the Global Definitions.pmh file.

- For SSI encoder with 24 position bits

```
Motor[1].pAbsPos = Gate3[0].Chan[0].SerialEncDataA.a
Motor[1].AbsPosFormat = $01001800
Motor[1].AbsPosSF = 1
Motor[1].PowerOnMode = 4
```

- For Mitutoyo encoder

```
Motor[1].pAbsPos = Gate3[0].Chan[0].SerialEncDataA.a
Motor[1].AbsPosFormat = $01002000
Motor[1].AbsPosSF = 1
Motor[1].PowerOnMode = 4
```

- For EnDat 2.1/2.2 encoder with 37 position bits

```
Motor[1].pAbsPos = Gate3[0].Chan[0].SerialEncDataA.a
Motor[1].AbsPosFormat = $01002500
Motor[1].AbsPosSF = 1
Motor[1].PowerOnMode = 4
```

4 Downloading the project

Right click on the **Solution Explorer** project name at the upper right of the IDE screen, select **Build and Download All Programs**, and execute Build and Download.

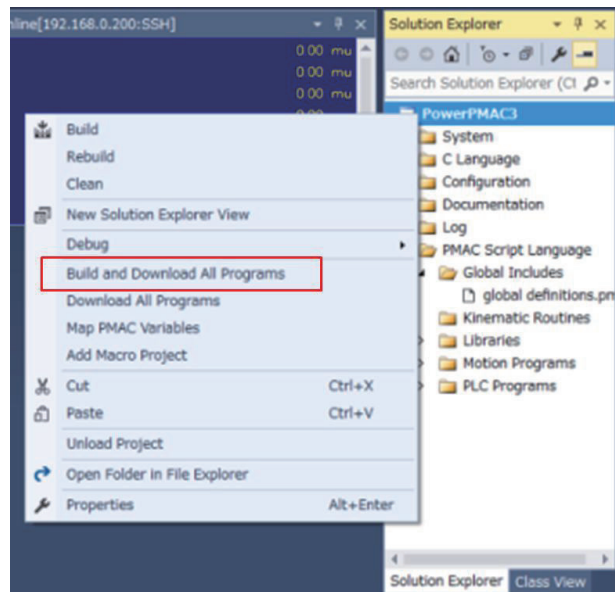

5 Make sure that there are no errors in the Output Window.

- If the transfer failed, check the content of the error in the Output Window. If there is a program error, re-view the program.

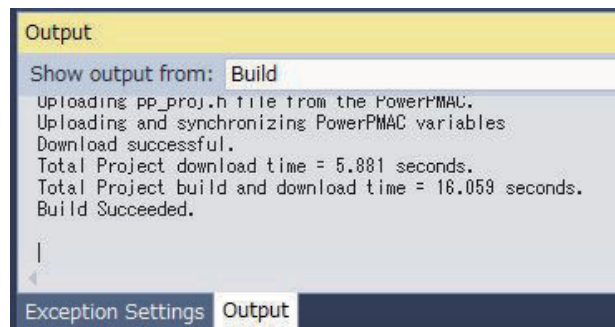

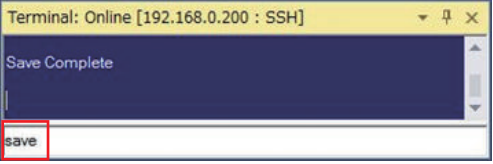
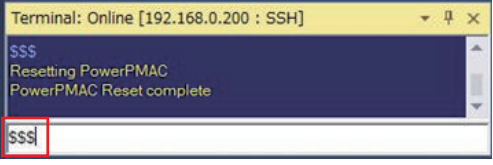
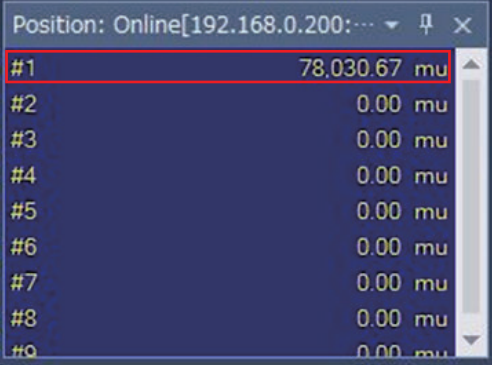
6	<p>Type the save command in the Power PMAC IDE Terminal.</p> <p>When the save is completed, "Save Complete" is displayed in the Terminal.</p>	
7	<p>Type the \$\$\$ command in the Power PMAC IDE Terminal.</p>	
8	<p>Make sure that the current position is reflected in the Power PMAC IDE Watch window.</p>	



Precautions for Correct Use

- If the **save** command is not successfully completed, the transferred project is not saved in the Controller. If the power to the Controller is switched OFF without the project being saved, the transferred project is destroyed.
- The maximum data rate is stipulated for each Serial Encoder. Use encoders within the following specification ranges.

SSI	2.0 Mbps
Mitutoyo	2.5 Mbps
EnDat 2.1/2.2	4.0 Mbps

4

Serial Encoder Status and Error Information

This section describes the status and error information of serial encoders. These information are stored in Gate3[i].Chan[j].SerialEncDataB. For more information, refer to the *Power PMAC Software Reference Manual (Cat. No. 0015)* provided by DT.

4

4-1	SSI Encoder Error Information	4-2
4-2	Mitutoyo Encoder Status and Error Information	4-3
4-3	EnDat 2.1/2.2 Encoder Status and Error Information	4-4

4-1 SSI Encoder Error Information

For the SSI encoder, Gate3[i].Chan[j].SerialEncDataB is defined as follows.

31	30	29	28	27	26	25	24	23	22	21	20	19	18	17	16	15	14	13	12	11	10	9	8	7	6	5	4	3	2	1	0
E	-	-	-	-	-	-	-	-	-	-	-	-	-	-	-	-	-	-	-	-	-	-	-	-	-	-	-	-	-	-	-
0																															
PE																															

E0 in Bit 31 represents the parity error bit.

For the settings to enable/disable the parity check and the parity type (odd parity, even parity) settings, set Gate3[i].Chan[j].SerialEncCmd according to the encoder specifications.

4-2 Mitutoyo Encoder Status and Error Information

For the Mitutoyo encoder, Gate3[i].Chan[j].SerialEncDataB is defined as follows.

31	30	29	28	27	26	25	24	23	22	21	20	19	18	17	16	15	14	13	12	11	10	9	8	7	6	5	4	3	2	1	0
E	E	-	-	F	F	F	F	A	A	A	A	A	A	A	A	ID	ID	ID	ID	ID	ID	ID	ID	-	-	-	-	-	-	-	-
1	0			3	2	1	0	7	6	5	4	3	2	1	0	7	6	5	4	3	2	1	0								
Err Bits		Status Field				Alarm Code								Encoder ID																	

Bits En in Bit 30 and 31 represent the communication error bits, with each bit having the following meaning:

- E0: CRC error
- E1: Timeout error

If a CRC error caused by the influence of noise occurs when each communication error bit is monitored by the user program, it is necessary to build a program that only considers it abnormal when three consecutive errors are detected. If this still occurs frequently, the influence of noise is likely large, so reduce the noise levels by taking countermeasures such as strengthening the shield and grounding and changing the wiring.

Bits Fn in Bit 24 to 27 represent the status field bits reported by the encoder, with each bit having the following meaning:

- F0: Fatal (unrecoverable) encoder error
- F1: Reserved
- F2: Illegal command code from controller
- F3: Reserved

Bits An in Bit 16 to 23 represent the alarm code notified from the encoder. The meaning of each bit differs depending on the encoder model. For details, refer to the encoder manual and the *Power PMAC Software Reference Manual (Cat. No. 0015)* provided by DT.

4-3 EnDat 2.1/2.2 Encoder Status and Error Information

For the EnDat 2.1/2.2 encoder, Gate3[i].Chan[j].SerialEncDataB is defined as follows.

31	30	29	28	27	26	25	24	23	22	21	20	19	18	17	16	15	14	13	12	11	10	9	8	7	6	5	4	3	2	1	0
E	E	E	-	-	-	-	-	-	-	-	-	-	-	-	-	P	P	P	P	P	P	P	P	P	P	P	P	P	P	P	P
2	1	0														47	46	45	44	43	42	41	40	39	38	37	36	35	34	33	32
TE	CE	EB																													

Bits En in Bit 29 to 31 represent the error code bits. Each bit has the following meaning:

E0: Error reported by the encoder

E1: CRC error

E2: Timeout error

If a CRC error caused by the influence of noise occurs when each communication error bit is monitored by the user program, it is necessary to build a program that only considers it abnormal when three consecutive errors are detected. If this still occurs frequently, the influence of noise is likely large, so reduce the noise levels by taking countermeasures such as strengthening the shield and grounding and changing the wiring.

Bits Pn in Bit 0 to 15 represent the single-turn and multi-turn position bits.

OMRON Corporation Industrial Automation Company

Kyoto, JAPAN

Contact : www.ia.omron.com

Regional Headquarters

OMRON EUROPE B.V.

Wegalaan 67-69, 2132 JD Hoofddorp
The Netherlands

Tel: (31) 2356-81-300 Fax: (31) 2356-81-388

OMRON ASIA PACIFIC PTE. LTD.

438B Alexandra Road, #08-01/02 Alexandra
Technopark, Singapore 119968

Tel: (65) 6835-3011 Fax: (65) 6835-2711

OMRON ELECTRONICS LLC

2895 Greenspoint Parkway, Suite 200
Hoffman Estates, IL 60169 U.S.A.

Tel: (1) 847-843-7900 Fax: (1) 847-843-7787

OMRON (CHINA) CO., LTD.

Room 2211, Bank of China Tower,
200 Yin Cheng Zhong Road,
PuDong New Area, Shanghai, 200120, China

Tel: (86) 21-5037-2222 Fax: (86) 21-5037-2200

Authorized Distributor:

©OMRON Corporation 2018 - 2023 All Rights Reserved.
In the interest of product improvement,
specifications are subject to change without notice.

Cat. No. R195-E1-02 0123